

Heller

CITROËN 5CV TRÈFLE

80702



Français

André Citroën veut produire un véhicule simple de conception, bon marché, allégé, sans compromettre sa robustesse. Après la type A, sort la B2, puis un modèle plus petit. Ce sera la 5cv Torpédo deux places, généralement peinte en jaune, ce qui lui vaudra le surnom de « petit citron ». Vint ensuite la Torpédo trois places, la position des passagers évoquant la forme d'un trèfle, elle fut surnommée ainsi pour cette raison.

La carrosserie du véhicule était en bois sur laquelle était clouée la tôle préformée. Les marchepieds étaient en aluminium et le sol de l'habitacle était recouvert d'un tapis brosse noir. La Citroën avait une seule porte du côté droit, le siège du conducteur était fixe alors que du passager était coulissant sur rails. La capote étanche s'appuyait sur des arceaux en frêne et son moteur de 850 cm³ pouvait propulser la voiture jusqu'à 60 km/h. 80250 exemplaires furent produits de 1922 à 1926.

Empattement	235 cm
Voie avant et arrière	118 cm
Longueur	325 cm
Largeur	134 cm
Poids	590 kg
Puissance	11 cv à 2100 t/mn

Deutsch

André Citroën wollte ein Fahrzeug mit einfacher Konzeption produzieren, das günstig und leicht wäre, ohne dabei die Robustheit zu kompromittieren. Nach dem Typ A erschien der B2 und danach ein kleineres Modell: Der zweisitzige Torpedo 5 CV, der normalerweise gelb lackiert war, wodurch er den Spitznamen „kleine Zitrone“ erhielt. Es folgte der Torpedo mit drei Sitzen, bei dem die Anordnung der Insassen an ein Kleeblatt erinnerte, und so erhielt er dieses als neuen Beinamen.

Die Fahrzeugkarosserie bestand aus Holz, auf dem das vorgeformte Blech aufgenagelt wurde. Die Pedale waren aus Aluminium und der Innenraumboden war mit einer schwarzen Fußmatte verkleidet. Der Citroën hatte nur eine Tür auf der rechten Seite, der Fahrersitz war festgestellt, der Beifahrersitz konnte jedoch auf Schienen verschoben werden. Das wasserdichte Verdeck stützte sich auf Eschensäulen und der Motor von 850 cm³ konnte das Auto auf bis zu 60 km/h beschleunigen. Von 1922 bis 1926 wurden 80.250 Exemplare produziert.

Radstand	235 cm
Spur vorne und hinten	118 cm
Länge	325 cm
Breite	134 cm
Gewicht	590 kg
Stärke	11 PS bei 2100 U/min.

Italiano

André Citroën volle produrre un veicolo di semplice concezione, a buon mercato, leggero, senza però compromettere la robustezza. Dopo la type A, esce la B2, quindi un modello più piccolo: la 5CV Torpedo a due posti, solitamente di colore giallo, caratteristica che le valse il soprannome di "petit citron" (piccolo limone). Venne quindi la Torpedo a tre posti, soprannominata "Trèfle" (trifoglio) perché la posizione dei passeggeri ricordava la forma di un trifoglio. La carrozzeria del veicolo era in legno, su cui era inchiodata la lamiera preformata. I predellini erano in alluminio e il pavimento dell'abitacolo era ricoperto da uno zerbino nero. La Citroën era dotata di una sola porta dal lato destro; il sedile del guidatore era fisso, mentre quello del passeggero scorreva su binari. La capote impermeabile poggiava su archetti in frassino e il suo motore da 850 cc era in grado di portare la vettura fino a 60 km/h. Dal 1922 al 1926 furono prodotti 80 250 esemplari.

Interasse	235 cm
Carreggiata anteriore e posteriore	118 cm
Lunghezza	325 cm
Larghezza	134 cm
Peso	590 kg
Potenza	11 CV a 2100 giri/min.

English

André Citroën wanted to produce a vehicle that was simply designed, low-priced and lightened, without compromising its sturdiness. After the type A, the B2 was launched, followed by a smaller model: the 5CV two-seat Torpedo, which was generally painted yellow, earning it the nickname of "little lemon". Then came the three-seat Torpedo, nicknamed the "cloverleaf" due to the shape of the passenger seating.

The car body was made of wood on which was nailed preformed sheet metal. The running boards were made of aluminium and the car's floor was covered by a black mat. The Citroën had a single door on the right side. The driver's seat was fixed in place while the passenger's seat slid on rails. The waterproof hood rested on ash wood hoops and its 850 cc engine powered the car to a top speed of 60 km/hr. From 1922 to 1926, 80,250 units were produced.

Wheelbase	235 cm
Front and rear track	118 cm
Length	325 cm
Width	134 cm
Weight	590 kg
Power	11 HP at 2,100 rpm

Español

Firme a sus convicciones, André Citroën se propone producir un vehículo de diseño sencillo, barato, ligero y a la vez robusto. Después de la serie A, vendría la B2 y, más tarde, un modelo más pequeño. Este sería el Torpedo biplaza de 5 CV; generalmente disponible en color amarillo, lo que le valió el apodo de "limoncito". Con posterioridad se produciría el torpedo tres plazas; en la que las plazas de asiento de los pasajeros recordaban la forma de un trébol y apodándose así por dicho motivo.

El bastidor del vehículo era de madera, sobre el que iban clavados los paneles preformados de la carrocería. Los estribos eran de aluminio y el piso del habitáculo estaba recubierto de una moqueta negra. Este Citroën poseía una sola puerta en el lado derecho. El asiento del conductor era fijo mientras que el del pasajero estaba montado sobre correderas. La capota impermeable descansaba sobre arcos de madera de fresno y su motor de 850 cm³ permitirá al vehículo alcanzar una velocidad de hasta 60 km/h. Llegarían a fabricarse 80 250 unidades entre 1922 y 1926.

Distancia entre ejes	235 cm
Distancia entre ruedas delante y atrás	118 cm
Longitud	325 cm
Ancho	134 cm
Peso	590 kg
Potencia	11 CV a 2100 r.p.m.







Nederlands

André Citroën wilde een voertuig bouwen met een eenvoudig ontwerp, die betaalbaar was en een verlaagd chassis had, en zonder hierbij aan stevigheid in te boeten. Na het type A, kwam er de B2, die kleiner was. Het was de 5cv Torpédo met twee plaatsen, die over het algemeen geel was geverfd, die de roepnaam "kleine Citroën" kreeg. Vervolgens kwam de Torpédo met drie plaatsen op de markt. De positie van de inzittenden deed denken aan een klaverblad, waardoor de auto deze roepnaam kreeg toegewezen.

De carrosserie van de wagen was van hout waarop het voorgevormde dak werd vastgespijkerd. De opstapjes waren van aluminium en de vloer binnenin het voertuig was bedekt met een zwarte borstelmat. De Citroën was slechts voorzien van één portier aan de rechterkant en de stoel van de bestuurder zat vast zodat de stoel van de passagier op stangen verschuifbaar was. De waterdichte motorkap rustte op bogen van essenhout en de motor van 850 cc kon de wagen tot een snelheid van 60 km/u voortstuwen. Tussen 1922 en 1926 werden er 80250 stuks van dit model gebouwd.

Wielbasis	235 cm
Voor en achter spoor	118 cm
Lengte	325 cm
Breedte	134 cm
Gewicht	590 kg
Vermogen	11 PK tot 2100 omw/mn



PEINTURES ESSENTIELLES / ESSENTIAL PAINTS



 5 Gris foncé brillant Gloss Dark grey Glänzend-Dunkelgrau	 11 Argent Silver Silber	 20 Bordeaux brillant Gloss crimson Glänzend- Karmesinrot	 21 Noir brillant Gloss black Glänzend -Schwarz	 33 Noir mat Matt black Mat t-Schwarz	 56 Aluminium Aluminium Aluminium
--	--	---	---	---	---

PEINTURES COMPLEMENTAIRES / ADDITIONAL PAINTS Disponibles séparément chez votre revendeur de maquette / available separately at your local hobby shop.

 10 Marron brillant Gloss brown Glänzend-Braun	 19 Rouge brillant Gloss red Glänzend- Rot	 34 Blanc mat Matt white Mat t-Weiss	 53 Gris métallique Gunmetal Metallgrau	 69 Jaune brillant Gloss yellow Glänzend -Gelb
--	--	--	--	--



1

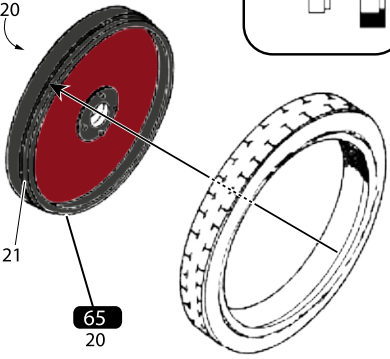

  **x2**

 





2

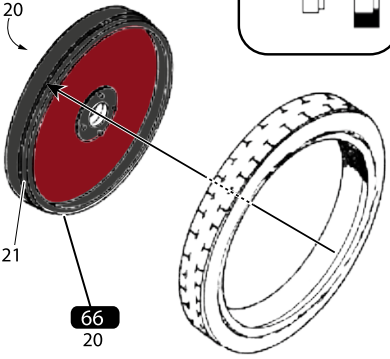

  **x2**

 





3

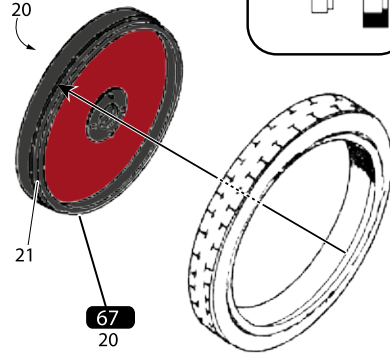

  **x2**



 



4



 



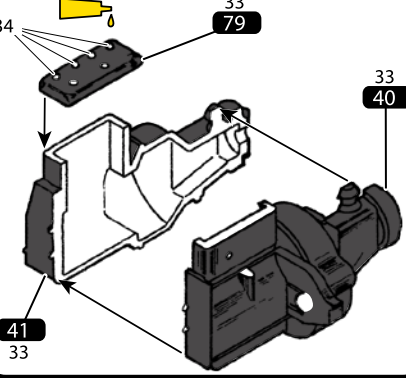

 



5



 

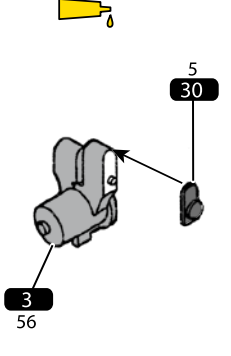



6





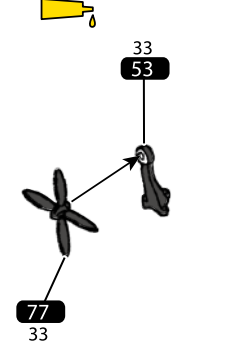



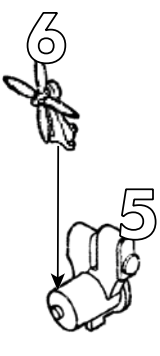

7



8



 

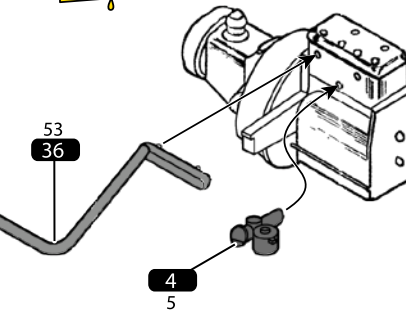

 



9







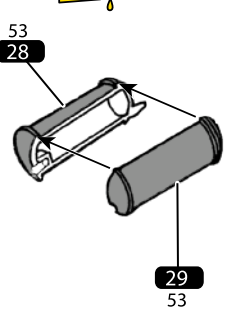



 







10

 

 

 



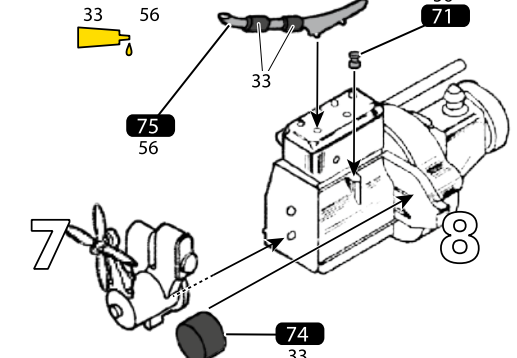

18

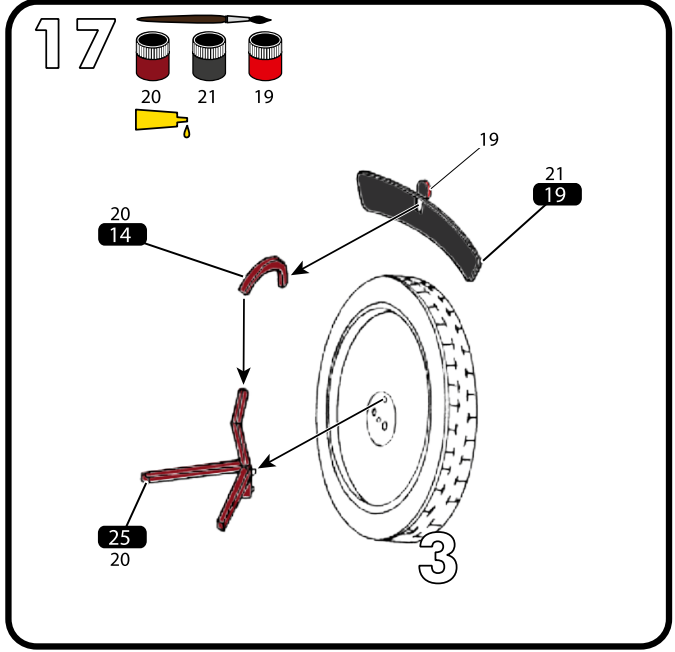
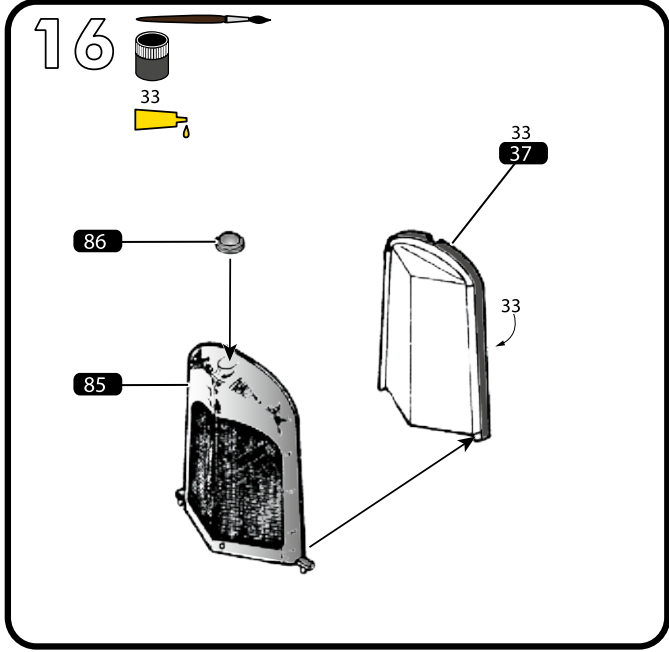
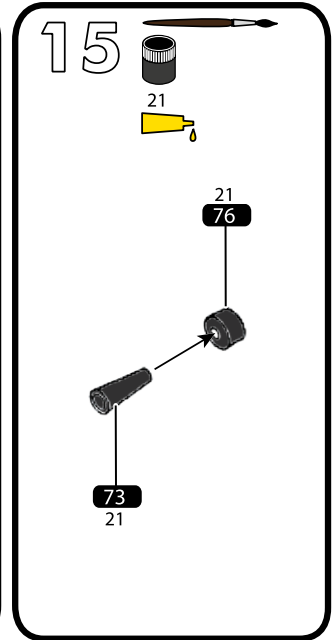
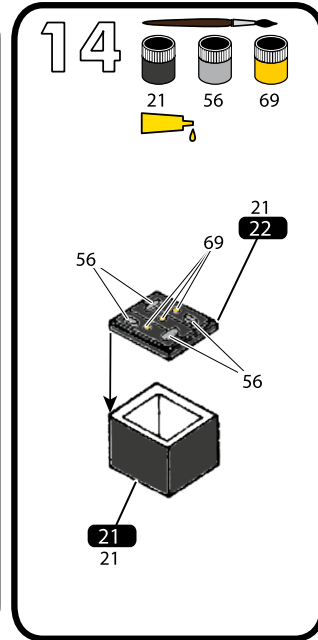
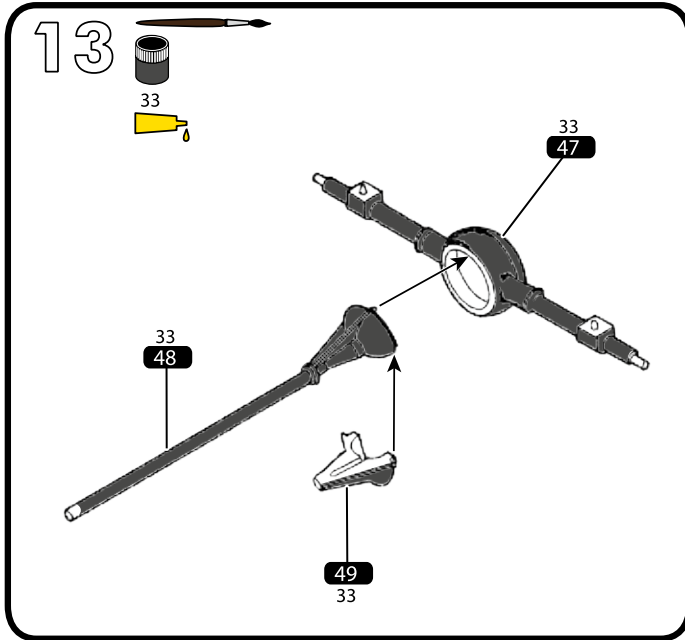
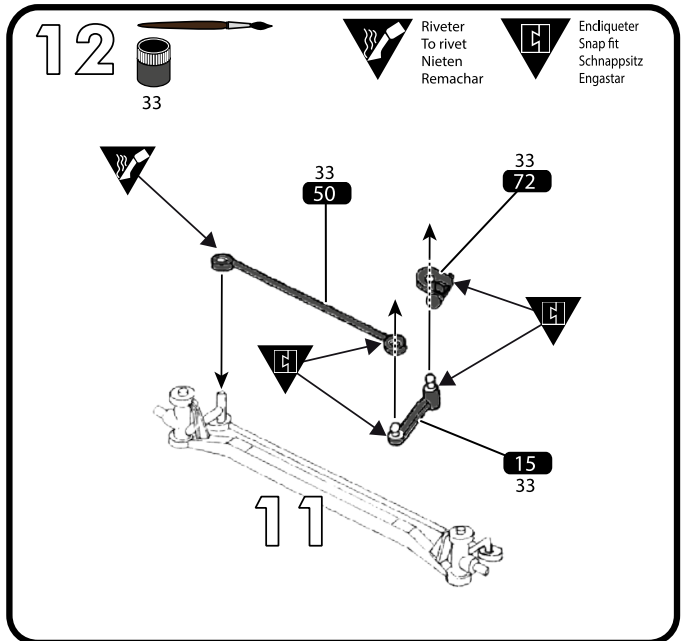
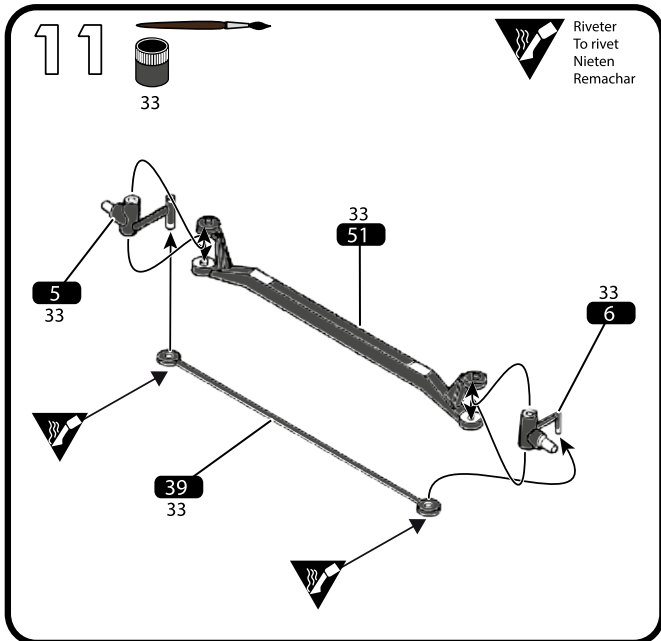

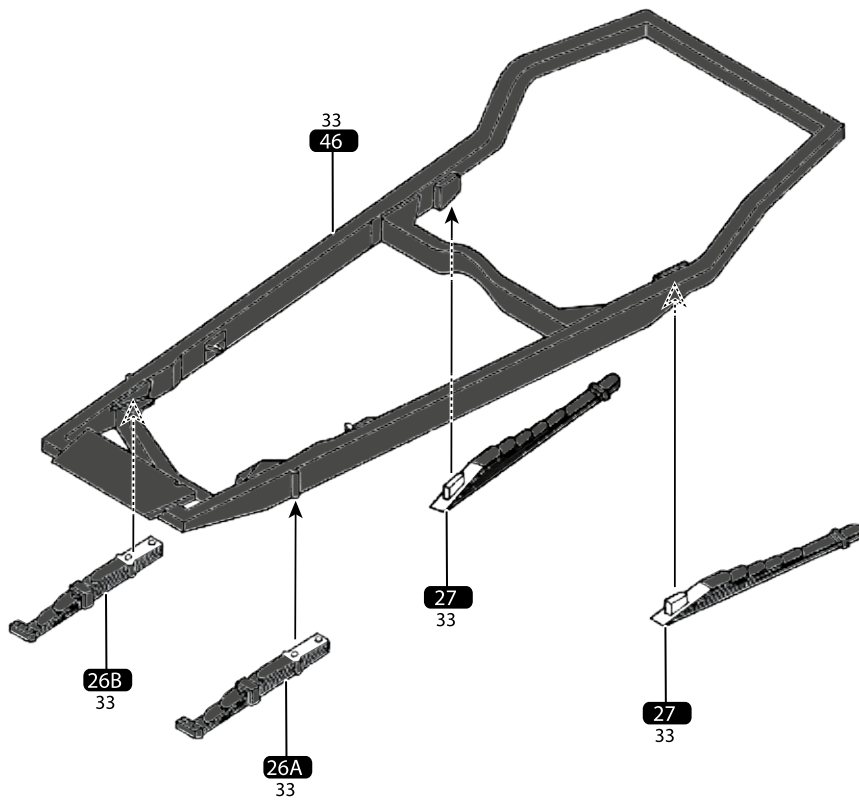
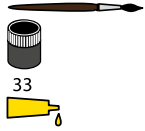
19

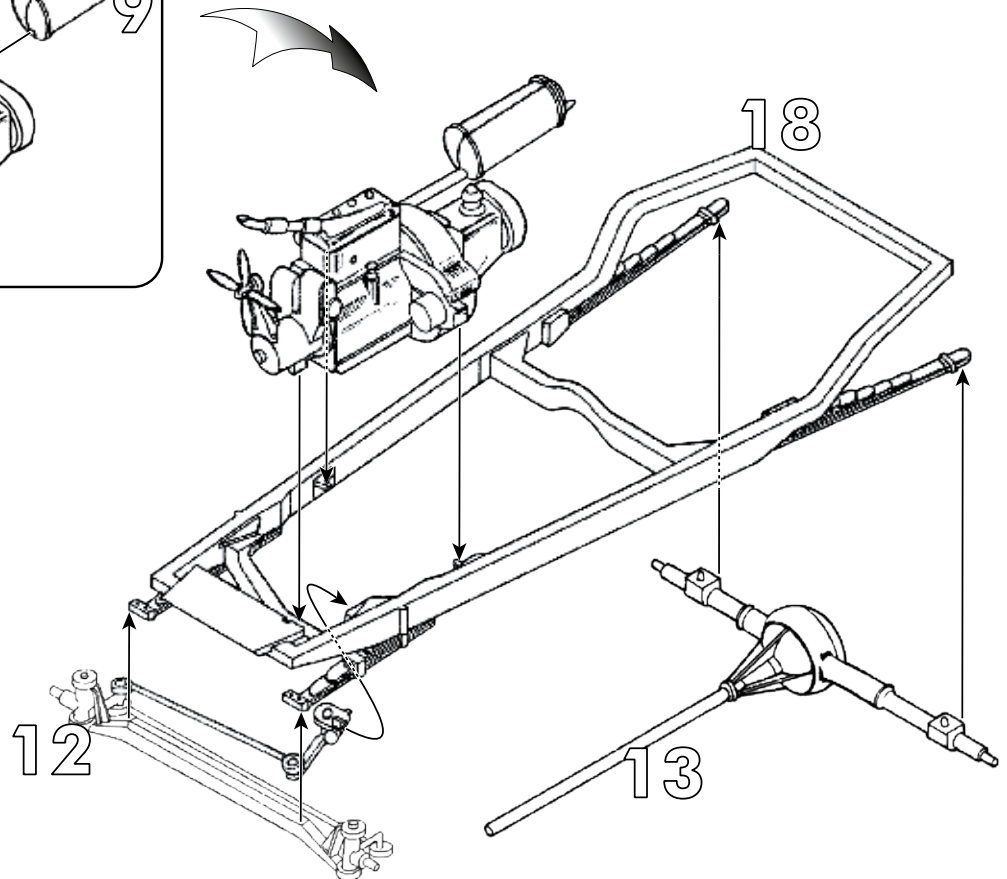
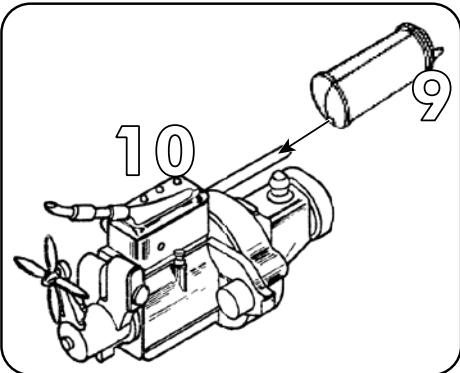

20

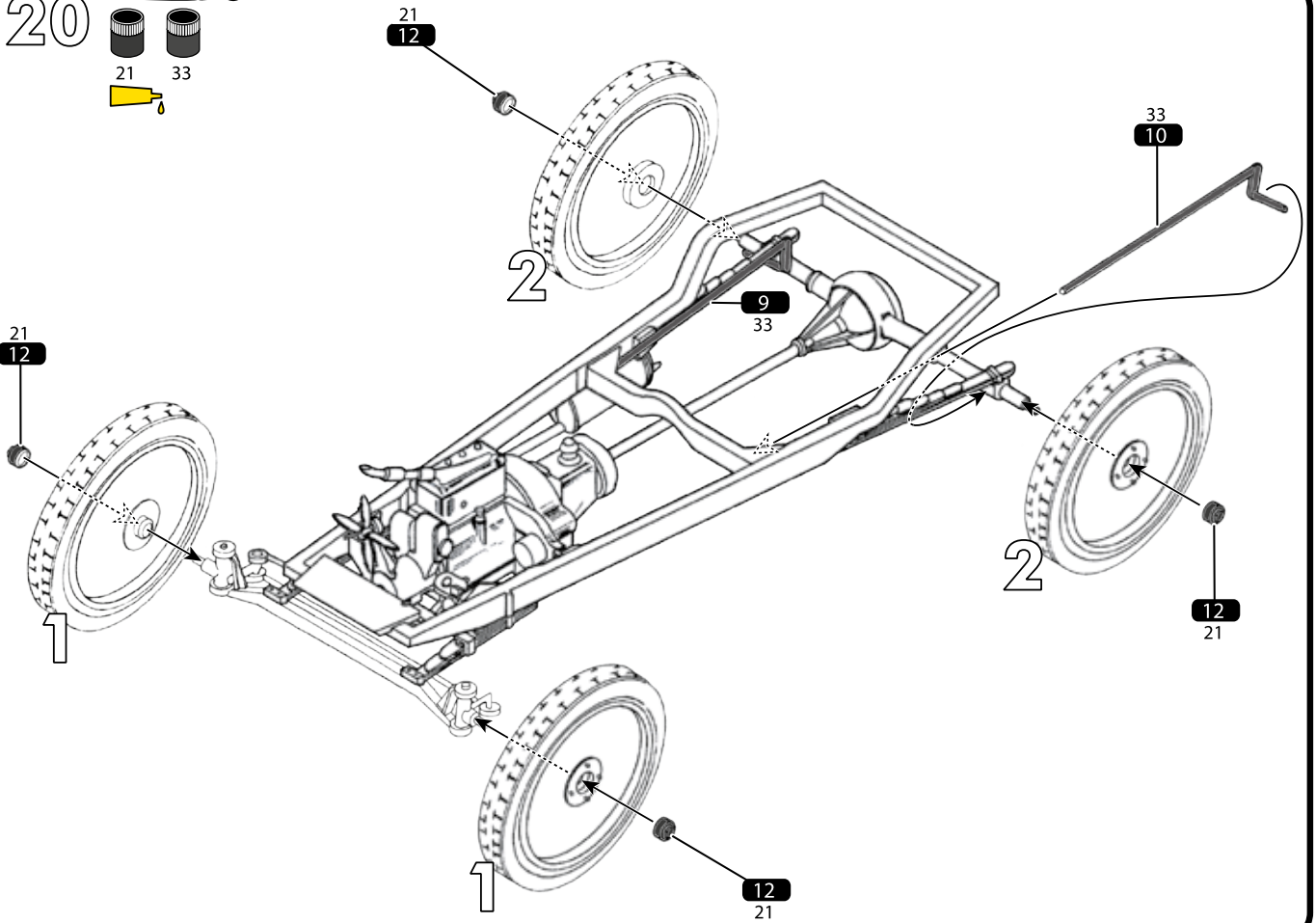
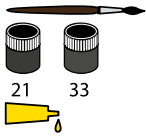

21

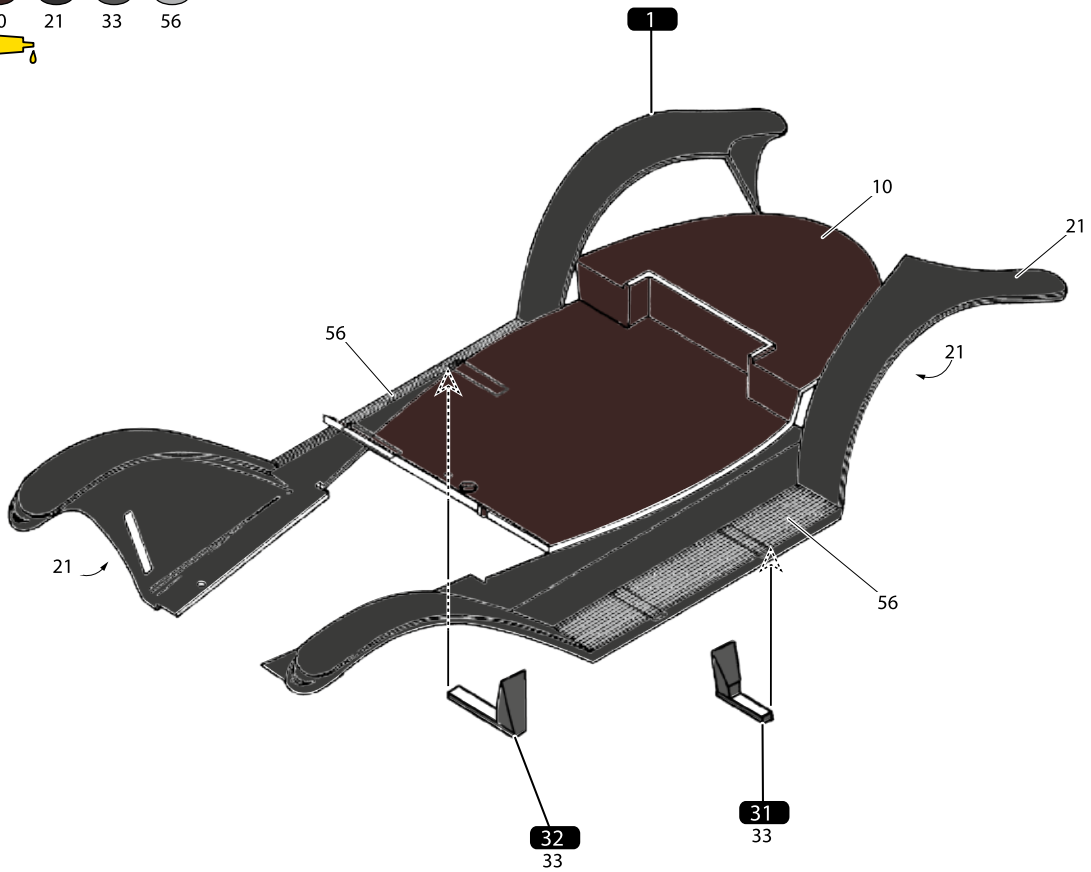
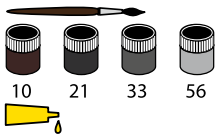

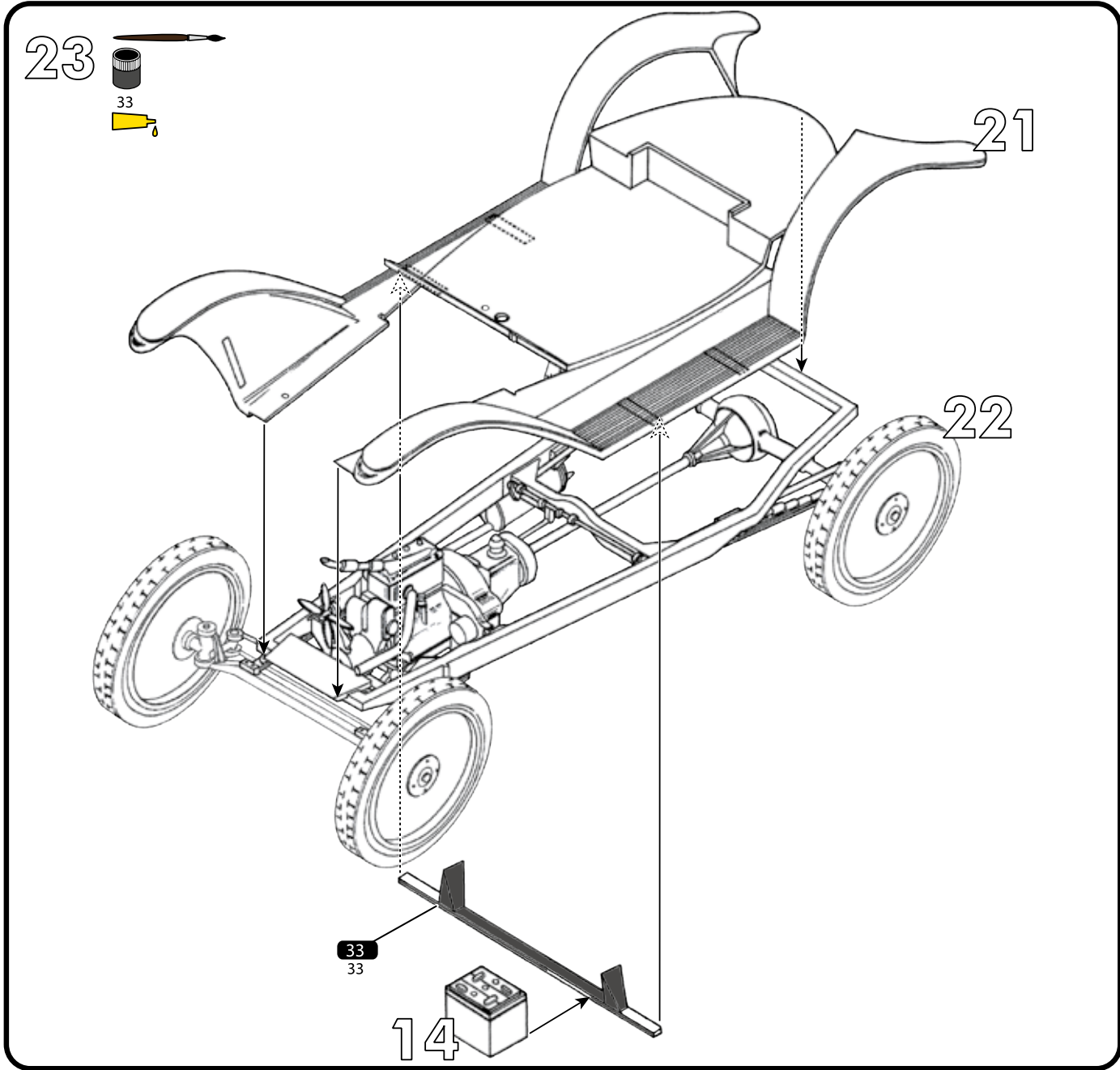
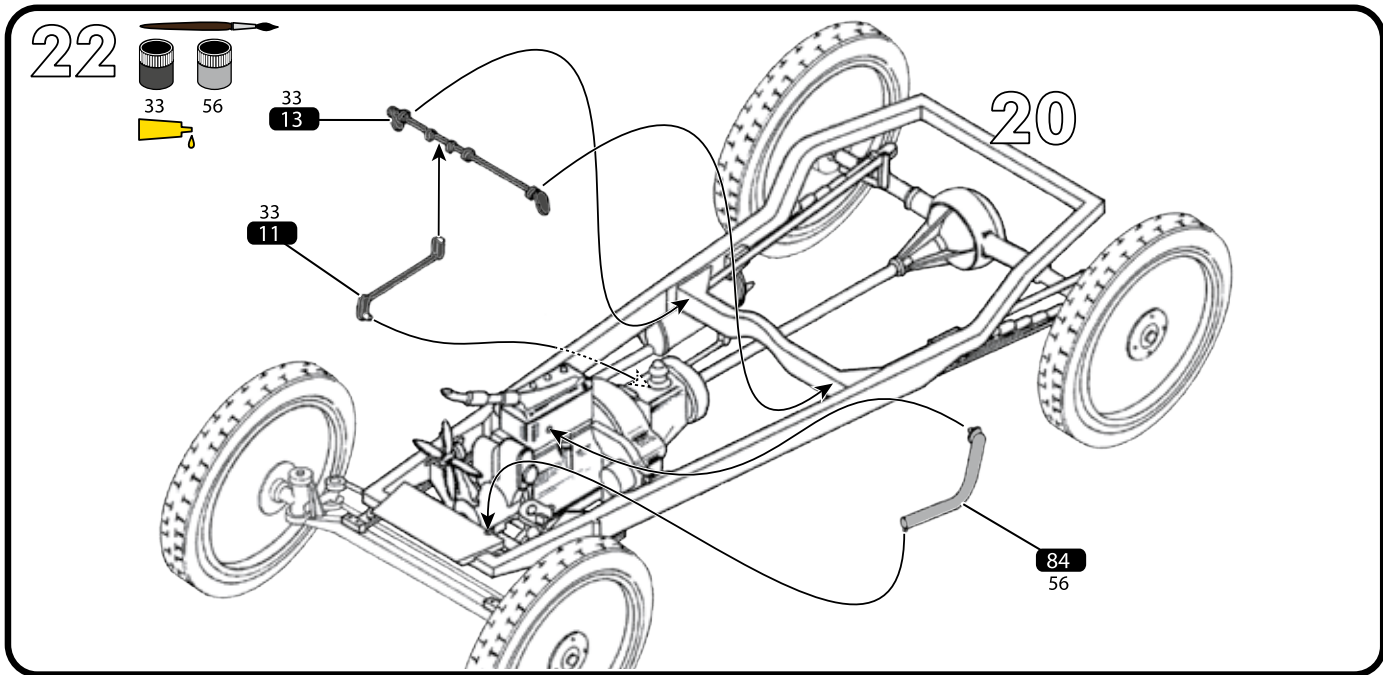

24

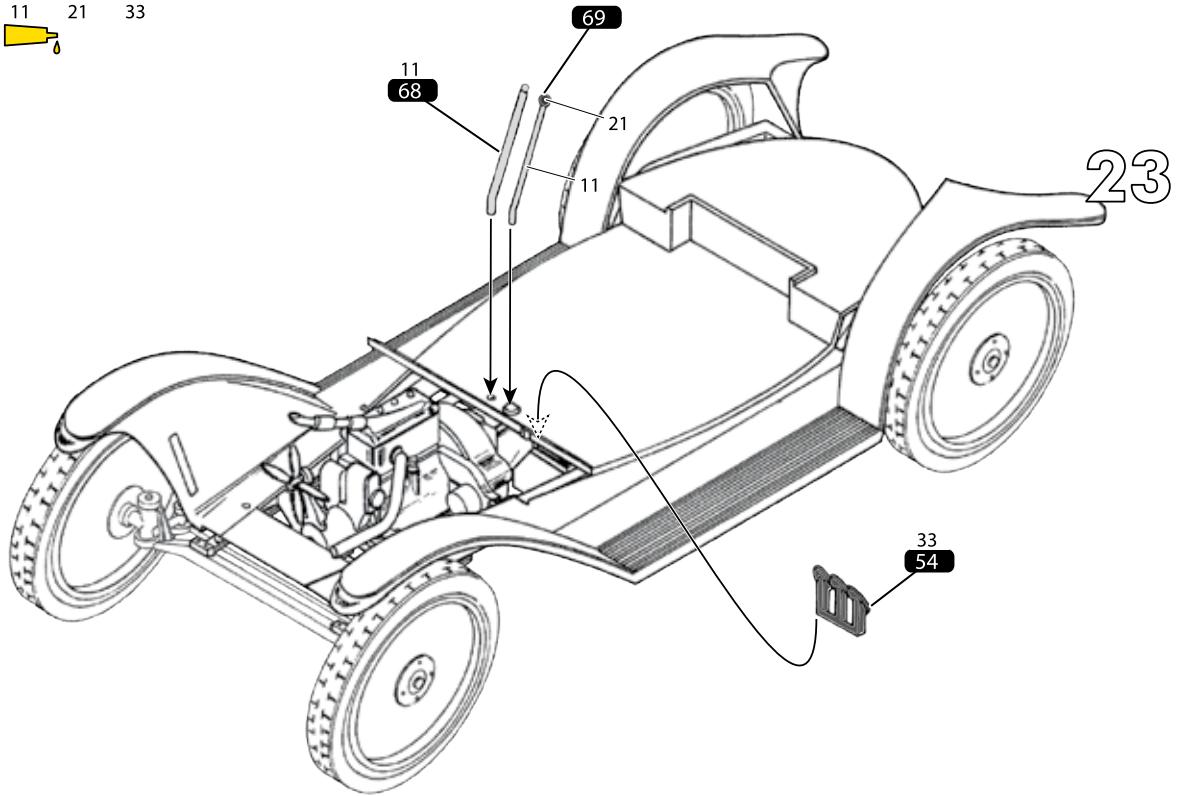
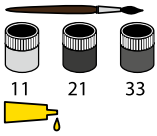

25

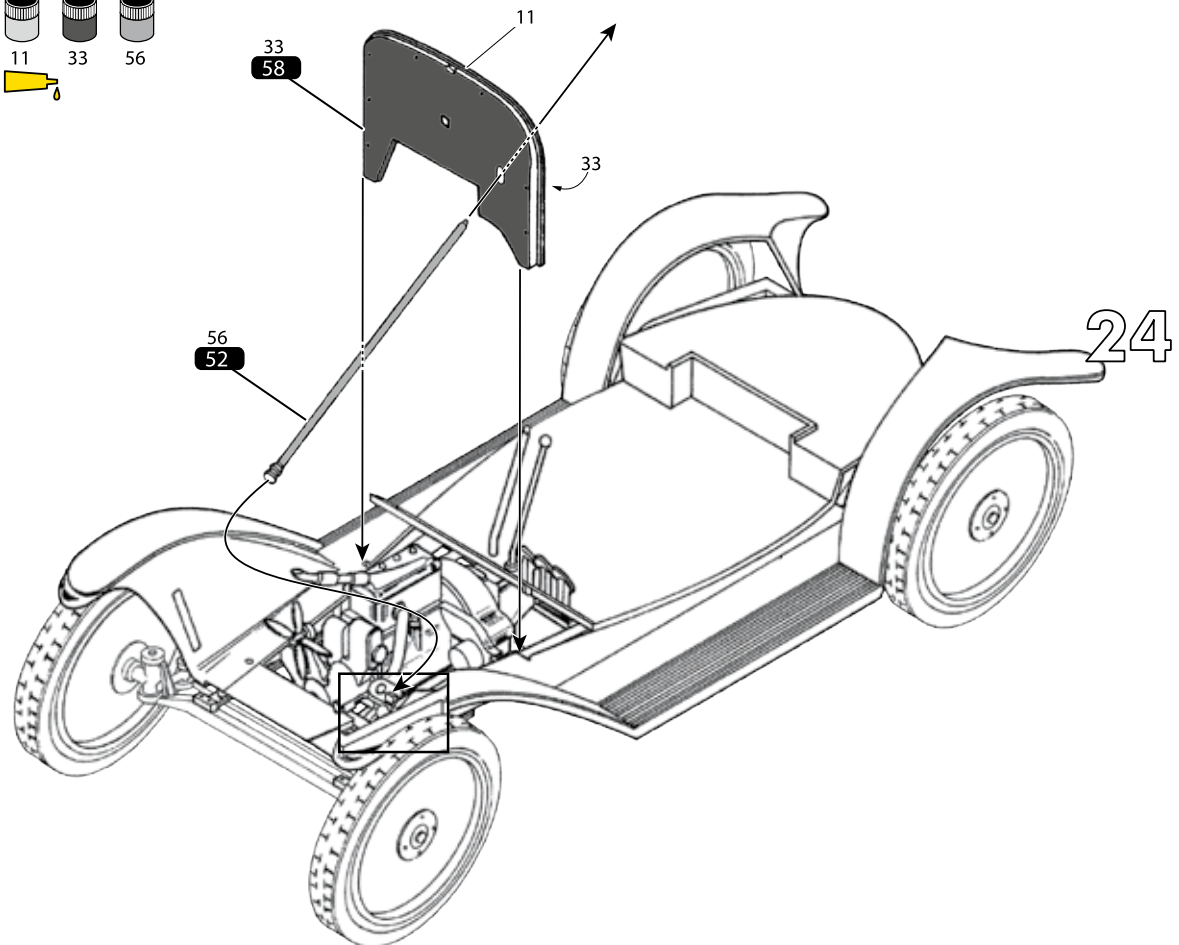
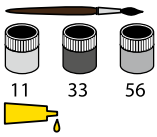

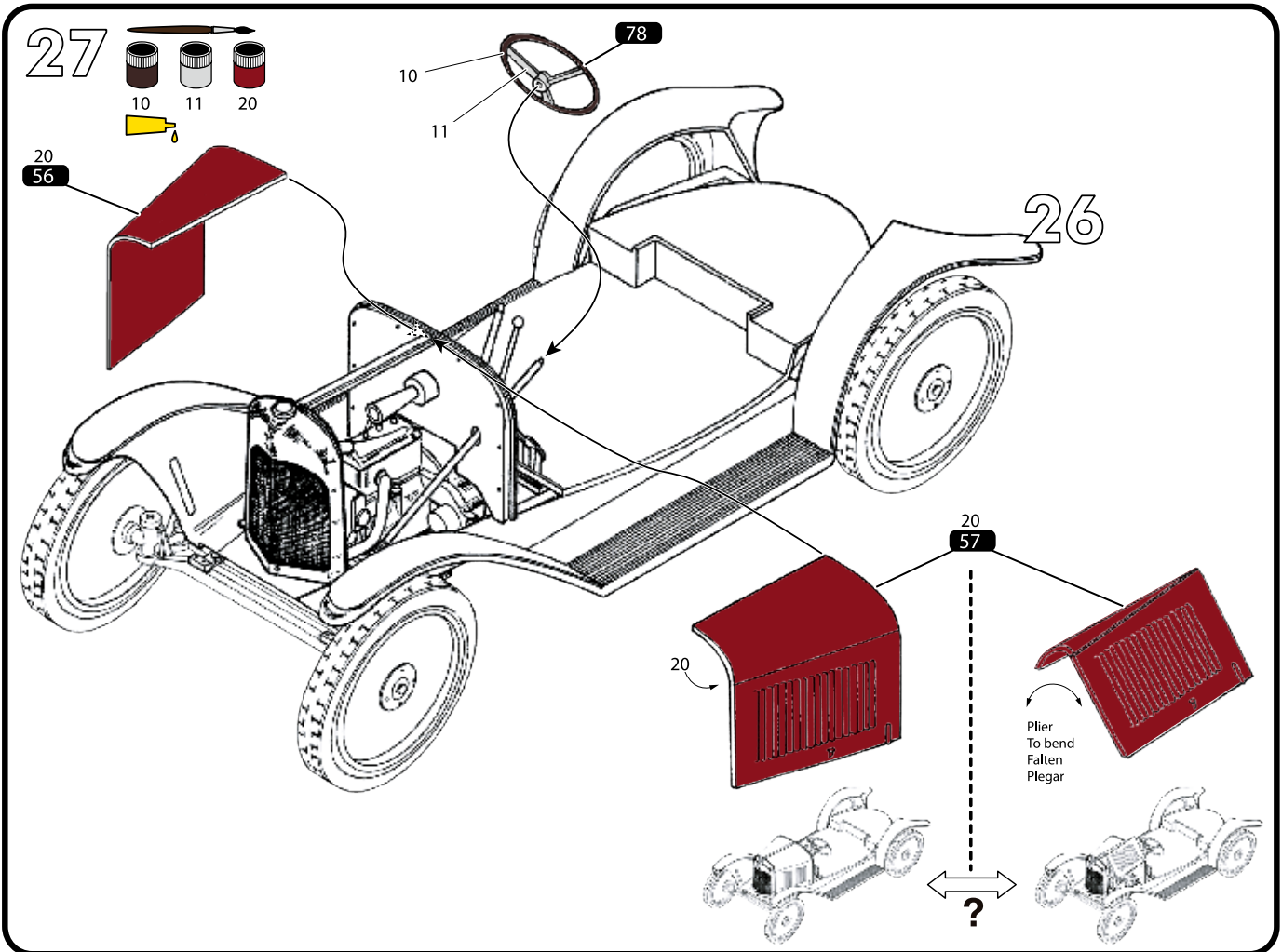
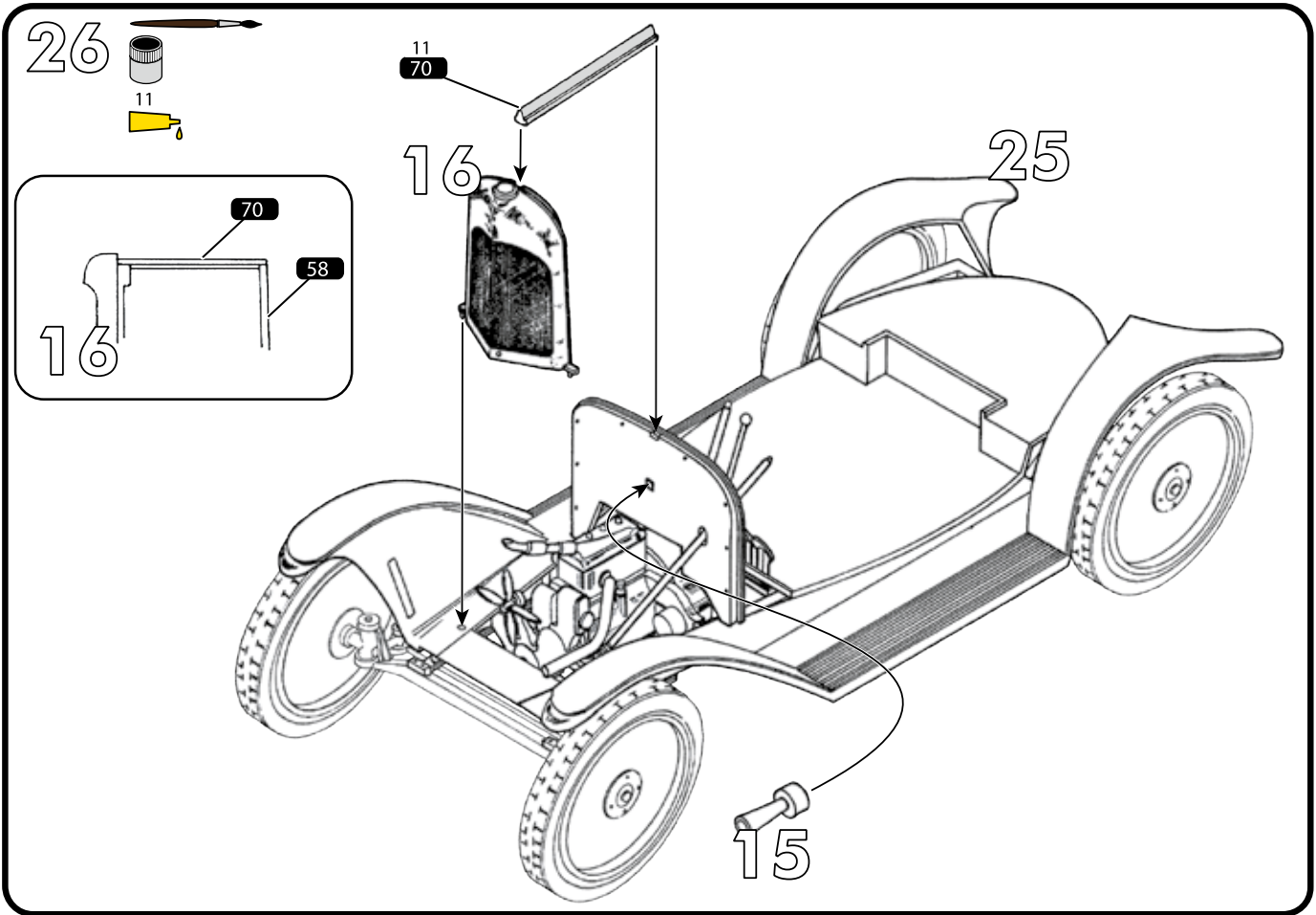

28

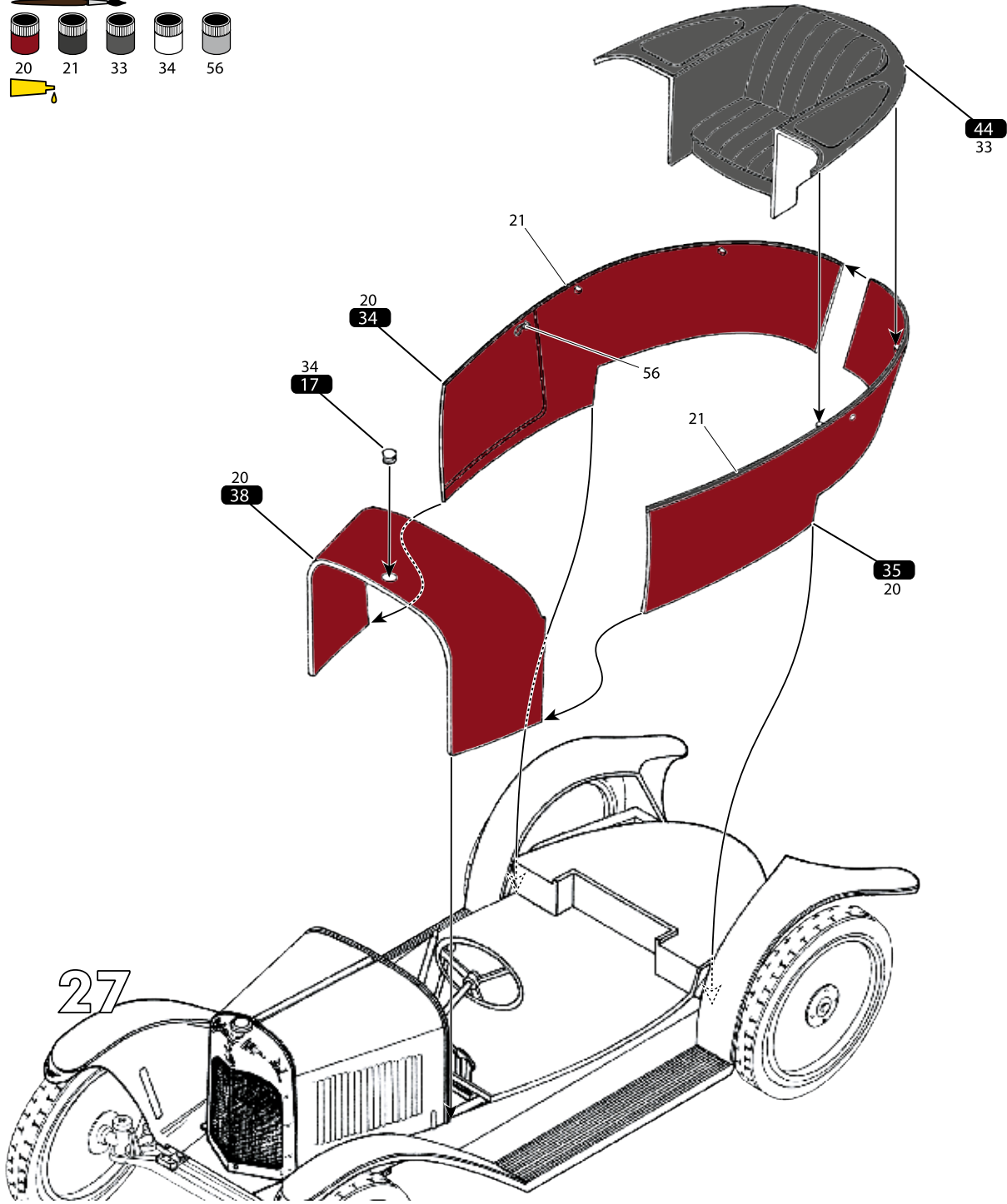
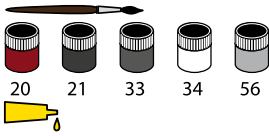

29

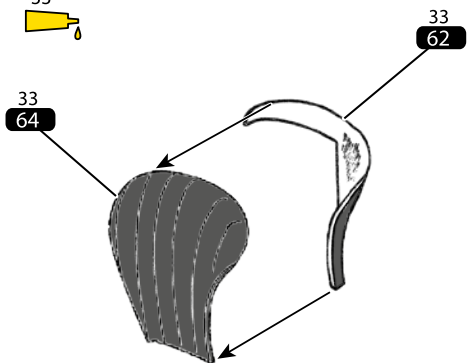
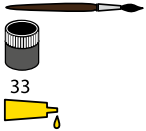

30

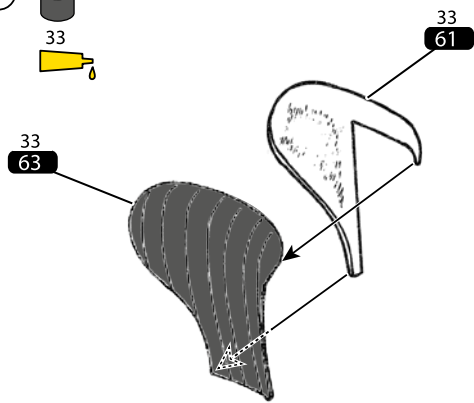
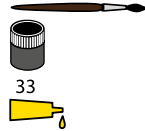

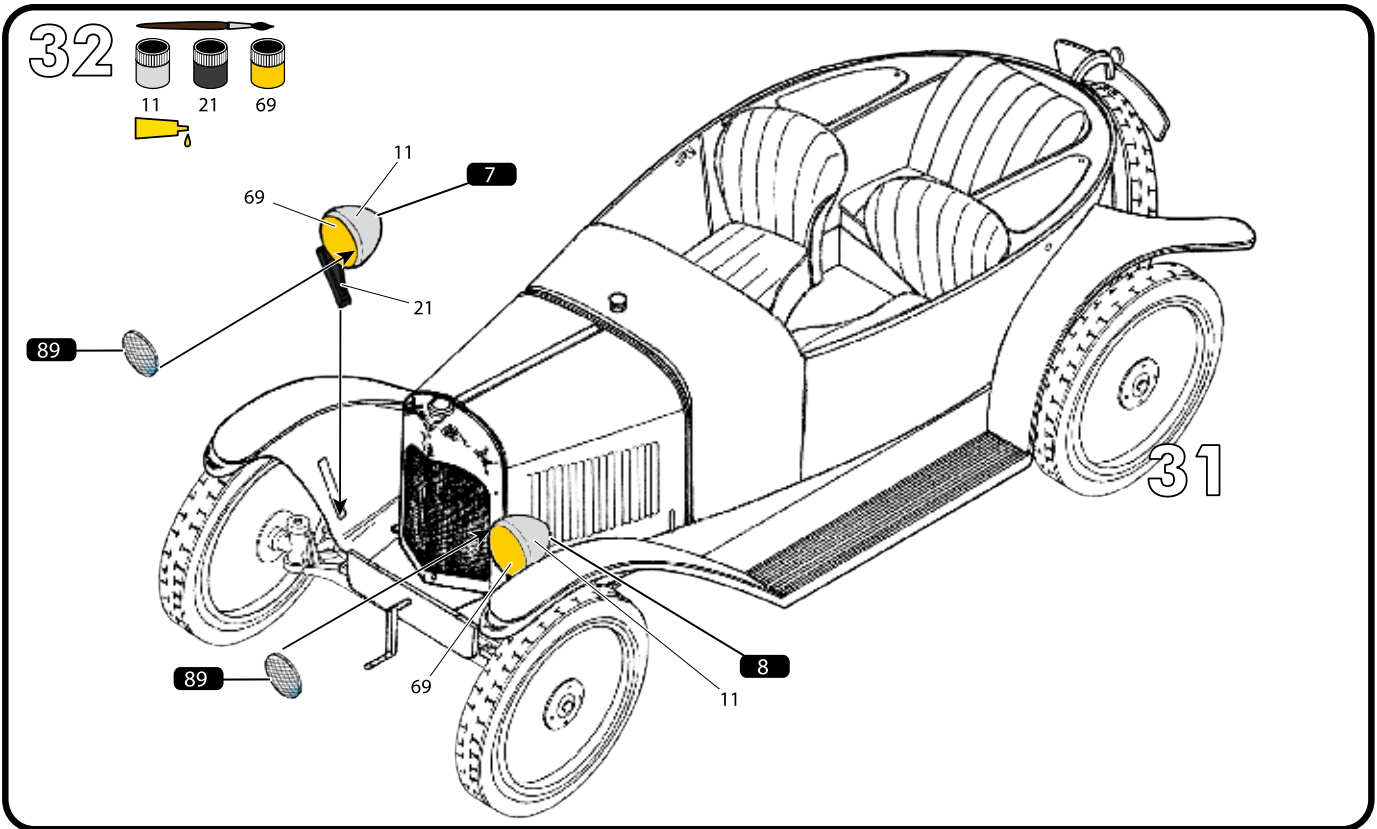
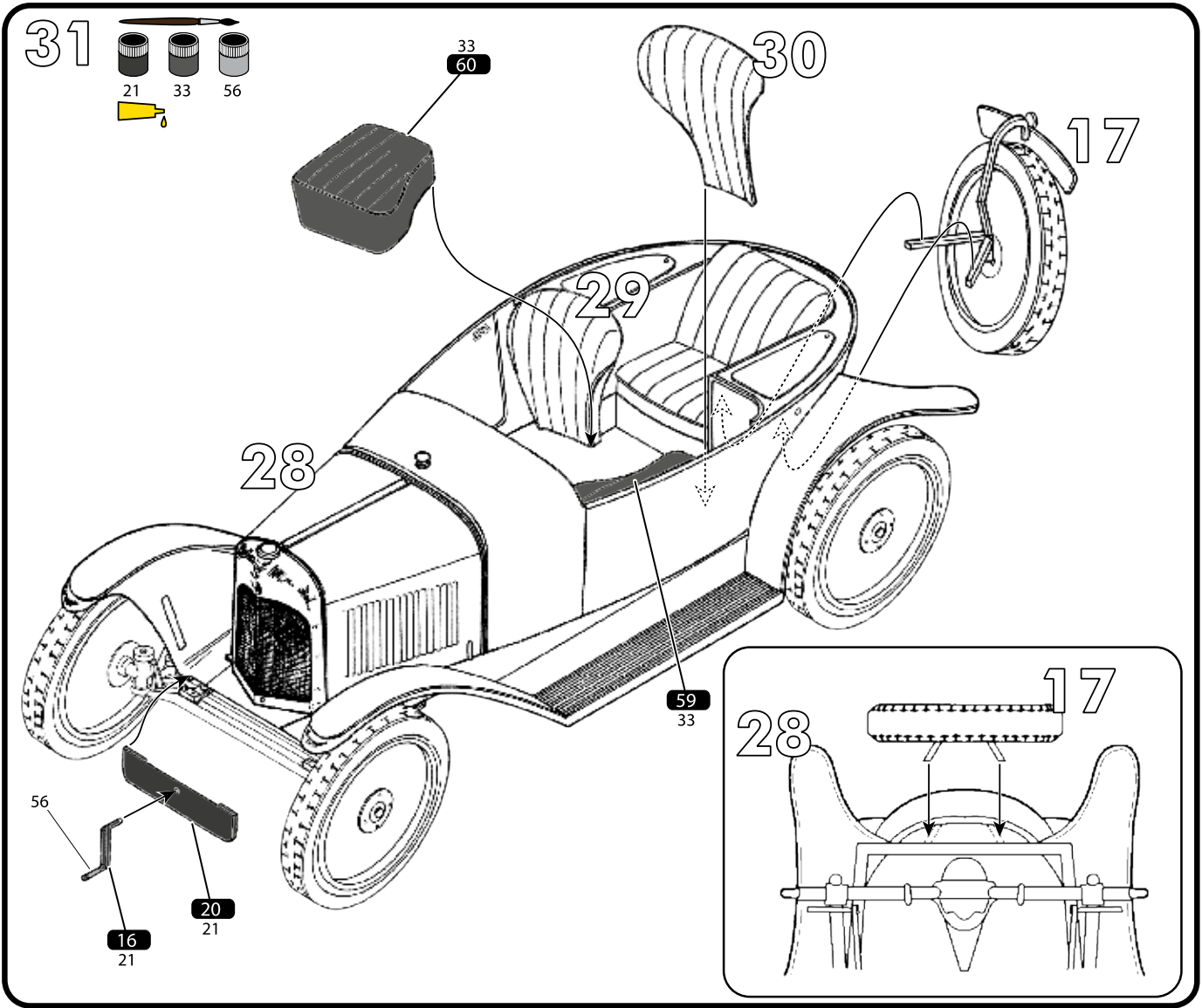

33

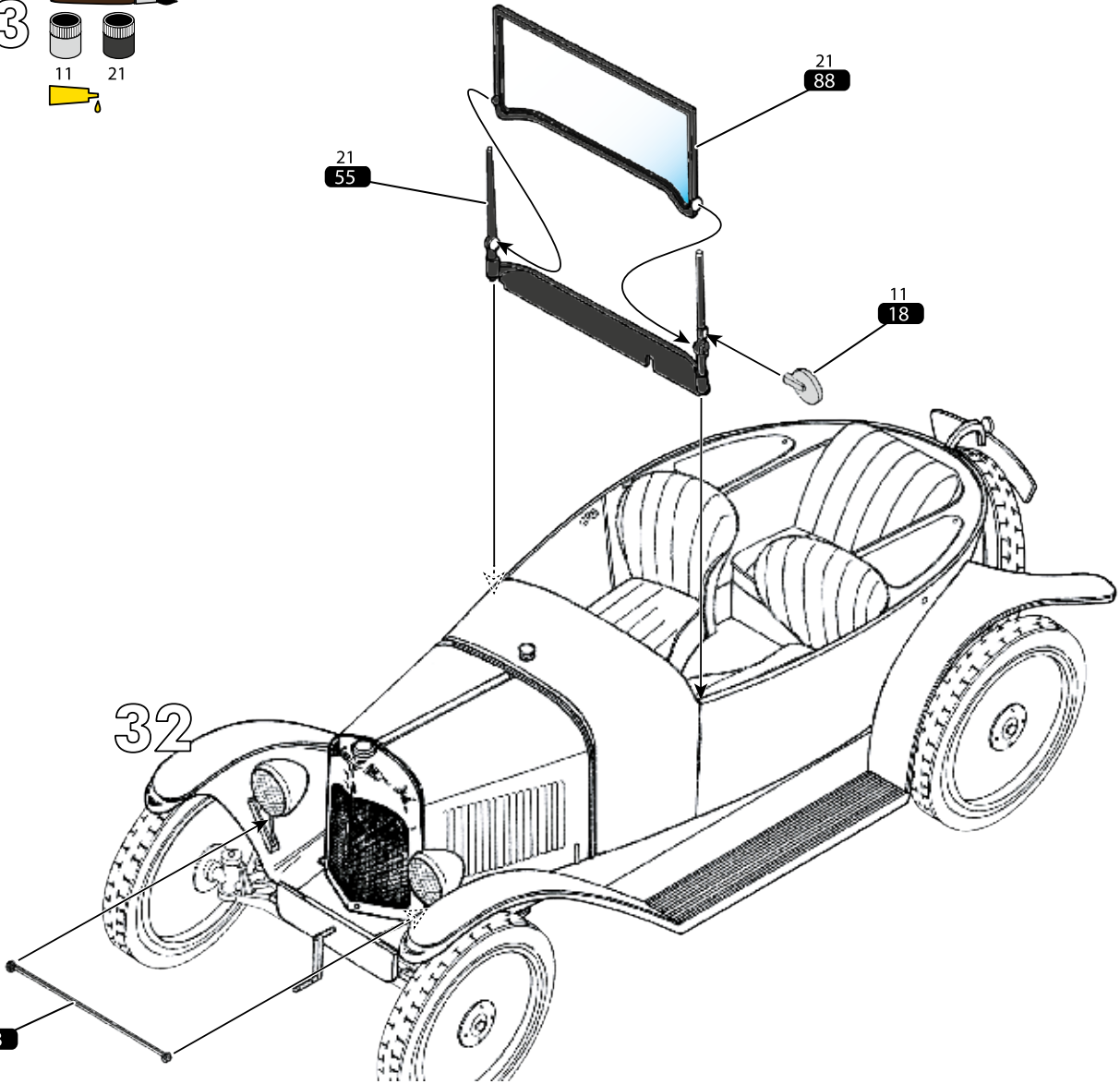
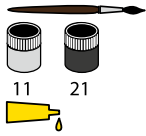

34

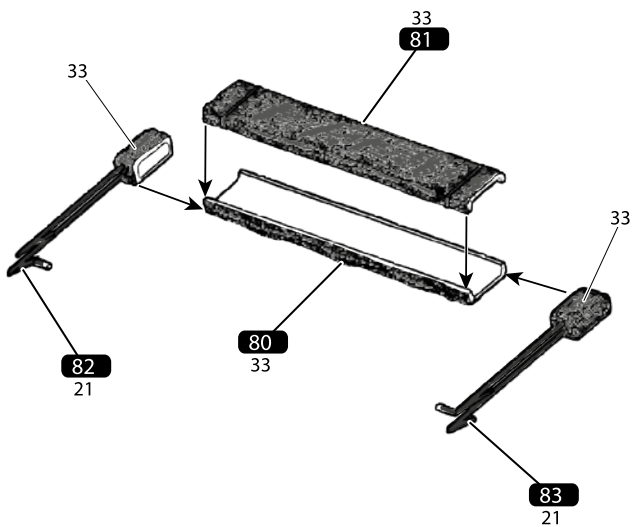
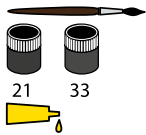

35

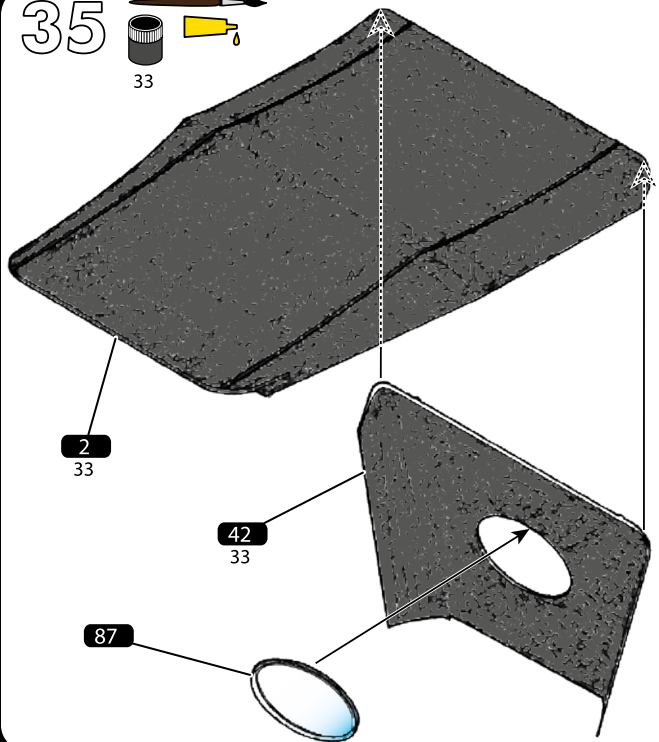

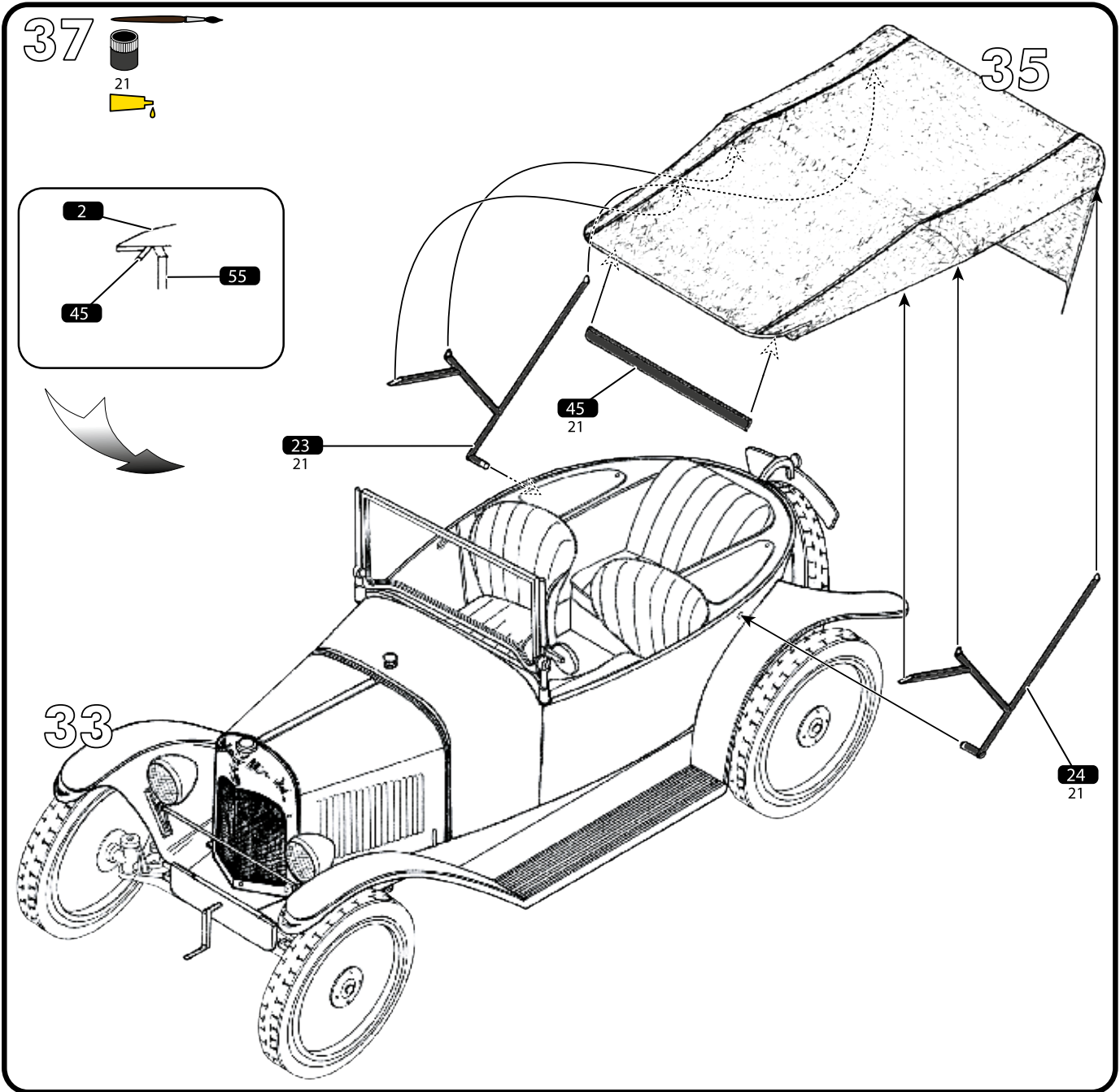
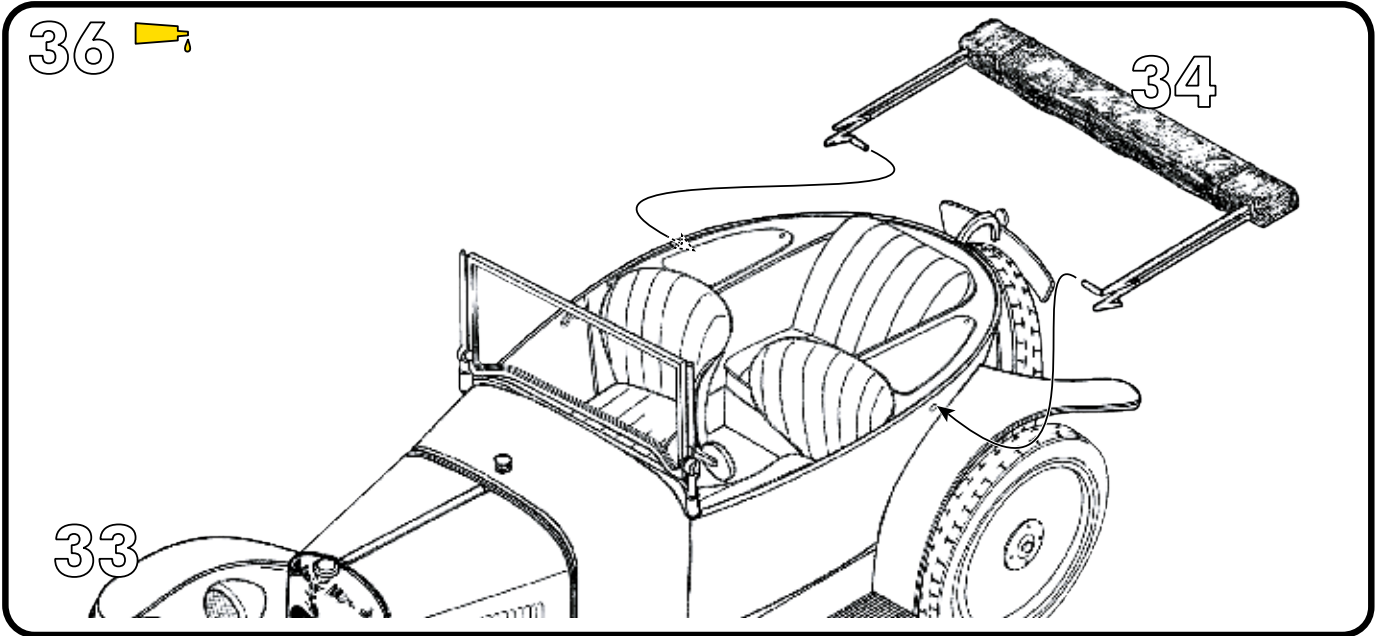

38

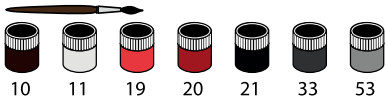

CITROËN 5CV Trèfle 1924

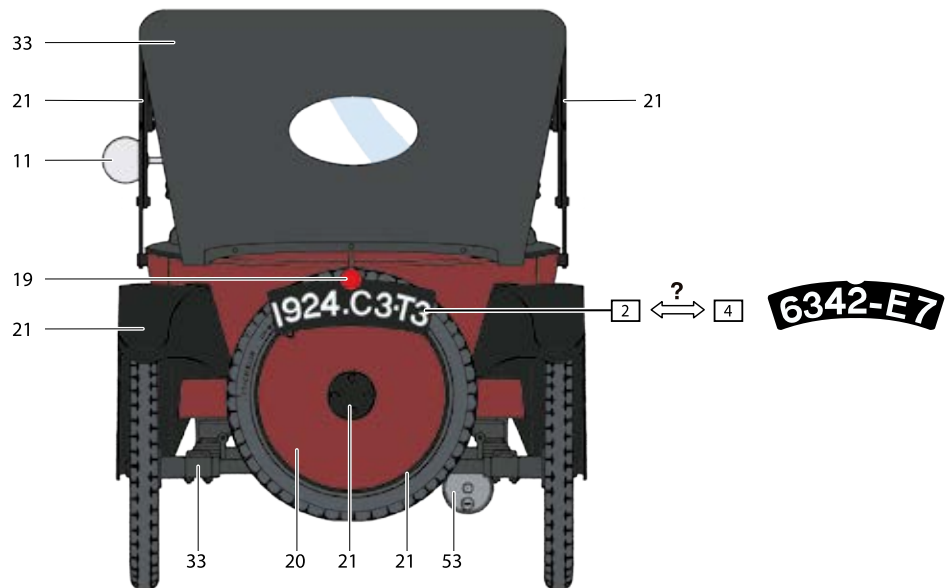
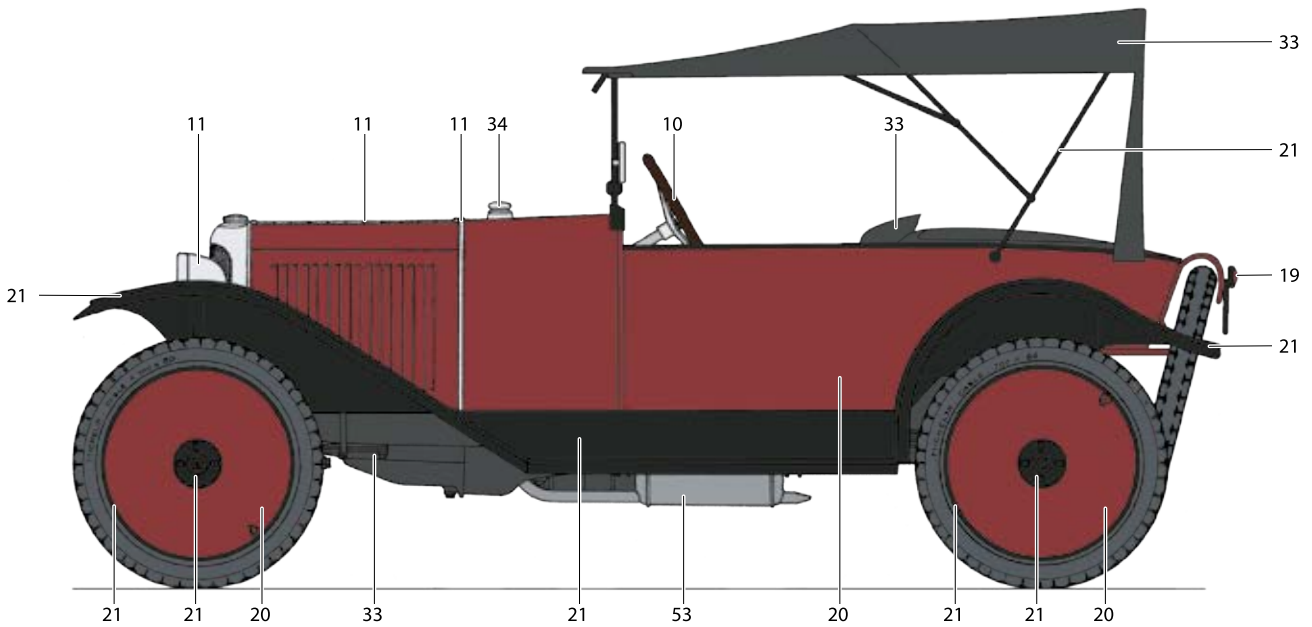
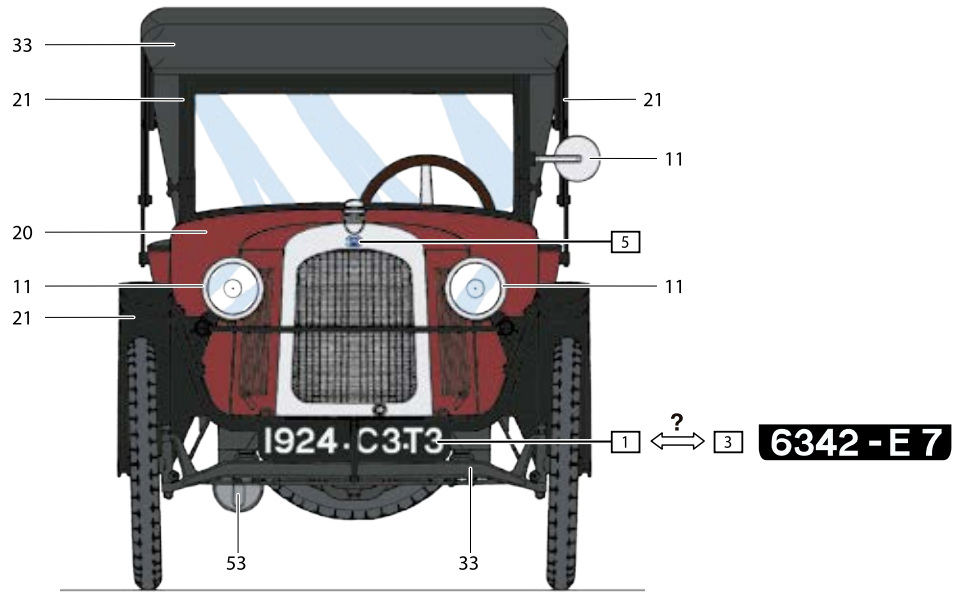

DÉCOUVREZ LE MONDE DES PEINTURES ACRYLIQUES HELLER !

ENTDECKEN SIE DIE WELT DER HELLER ACRYL-FARBEN!
DISCOVER THE WORLD OF HELLER ACRYLIC COLOURS!

NEW



- FACILE À UTILISER
- DILUABLE À L'EAU
- DES POTS DE PEINTURE STABLES
- BOUCHON À VIS SÉCURISÉ

- EASY TO USE
- WATER BASED
- STABLE PAINT CANS
- SECURE SCREW CAP

- EINFACHE ANWENDUNG
- MIT WASSER VERDÜNNBAR
- STANDFESTE FARBDOSEN
- SICHERER SCHRAUBVERSCHLUSS

VISITEZ-NOUS EN LIGNE!

VISIT US DIGITALLY!
BESUCHEN SIE UNS DIGITAL!

 www.heller.fr
 [instagram.com/heller.fr](https://www.instagram.com/heller.fr)
 [facebook.com/heller.fr](https://www.facebook.com/heller.fr)

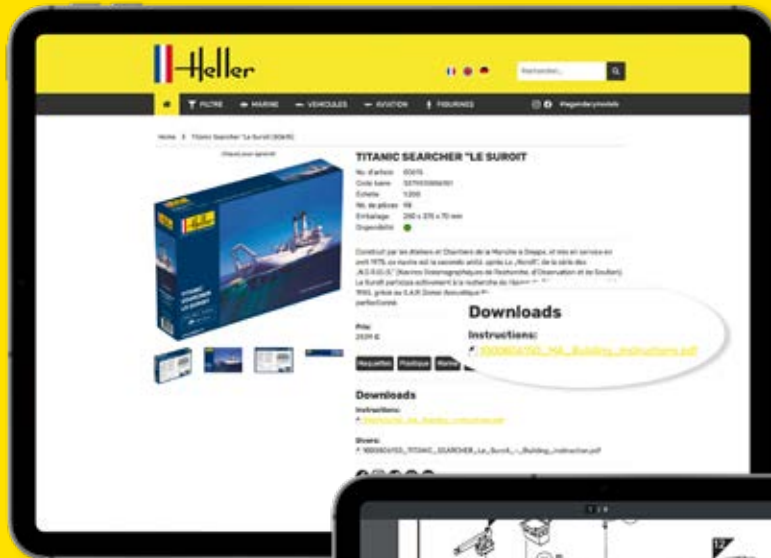

Choisissez l'article que vous désirez et téléchargez les instructions.
Choose your desired article and download the instruction.
Wählen Sie den gewünschten Artikel und laden Sie die Anleitung herunter.

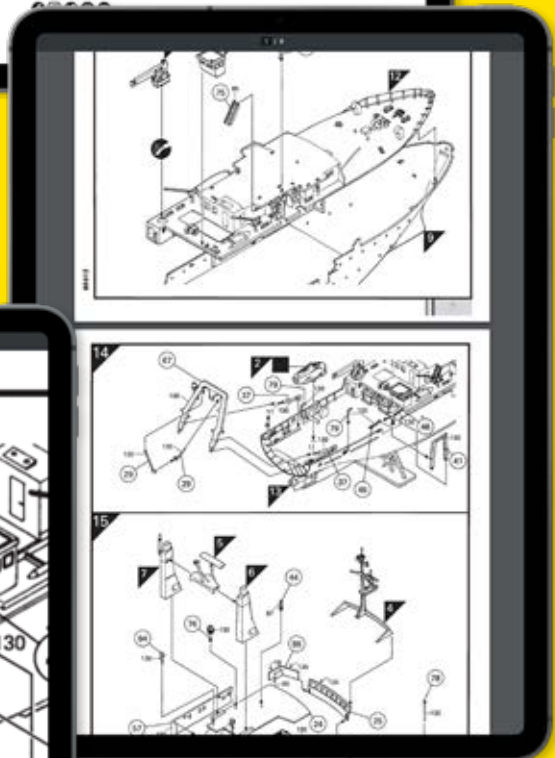

Download all instructions!

Grossissement des instructions pour une vue détaillée.

Enlarge the instruction for a more detailed view.



Vergrößern Sie die Anleitung für eine detailliertere Ansicht.

V-280121

Service Consommateurs
Pour toute demande de SAV, connectez-vous sur notre site www.heller.fr.

Customer Service
For after-sales service requests, please contact us through our website www.heller.fr.

Endverbraucherservice
Bitte besuchen Sie uns auf www.heller.fr für alle Ersatzteilanfragen.

Heller Hobby GmbH
Erlenbacher Str. 3 • 42477 Radevormwald • GERMANY
 +49 (0) 2195-92773-0  info@heller.fr