

M4A2 SHERMAN "DIVISION LECLERC"

79894

Français

Le Sherman est le char américain moyen le plus produit pendant la Seconde Guerre mondiale : près de 55 000 exemplaires sont réalisés dans des versions très variées. Le char moyen M4 Sherman constitua l'épine dorsale de la force blindée alliée. Les cinq principales variantes de M4 à M4A4 se différencient principalement par le type de caisse, le canon, et le moteur utilisés. Après la première épreuve des combats, des plaques de blindage supplémentaires seront ajoutées de chaque côté de la caisse, sur la droite de la tourelle et sur le glacis avant. Les M4A2, bénéficient d'un moteur diesel General Motors de 13,7 litres de cylindrée, le GM 6-71. Bien que disposant d'un canon de 75mm surclassé par les canons des panzers, le M4 compense ce déséquilibre par sa mobilité, sa fiabilité et surtout sa supériorité numérique. Char standard des Alliés, le Sherman sera employé sur tous les fronts jusqu'à la fin du conflit. Il jouera un rôle capital lors du Débarquement de 1944 et durant la bataille de Normandie.

| | |
|---------------------------------|--|
| Longueur caisse | 5.92 m |
| Largeur | 2.62 m |
| Hauteur | 2.74 m |
| Poids en ordre de combat | 31 800 kg |
| Blindage | Min: 25 mm Max: 89 mm |
| Équipage | 5 hommes |
| Armement principal | 1 canon de 75mm M34A1 |
| Armement secondaire | 1 mitrailleuse de 12.7 mm M2 HB 2 mitrailleuses de 7.62 mm M1919A4 1 mortier M3 de 2 pouces pour fumigènes |
| Motorisation | GM 6-71 |
| Boîte de vitesse | 5 vitesses avant, 1 arrière, toutes synchronisées |
| Capacité carburant | 662 litres |

English

The Sherman was the single most manufactured US medium tank during World War II, with approximately 55,000 vehicles produced, in a wide range of versions. The M4 Sherman medium tank formed the backbone of the Allied armoured forces. The five main variants, from the M4 to the M4A4, differ primarily in the type of body, gun and engine used. After the first combat trials, additional armour plates were added to each side of the body, to the right side of the turret and to the front sloped section. M4A2s were powered by the GM 6-71, a 13.7-litre General Motors cylinder diesel engine. Although its 75mm gun was outclassed by those fitted on Panzers, the M4 compensated for this imbalance with its mobility, reliability and above all, numerical superiority. As the standard Allied tank, the Sherman would be used on all fronts until the end of the war. It would play a crucial role in the 1944 D-Day landings and during the Battle of Normandy.

| | |
|---------------------------|--|
| Body length | 5.92 m |
| Width | 2.62 m |
| Height | 2.74 m |
| Combat weight | 31,800 kg |
| Armour-plating | Min: 25 mm Max: 89 mm |
| Crew | 5 crewmembers |
| Main armament | one 75mm M34A1 gun |
| Secondary armament | One 12.7 mm M2 HB machine gun Two 7.62 mm M1919A4 machine guns, One 2-inch M3 mortar for smoke munitions |
| Engine | GM 6-71 |
| Transmission | 5 gears forward, 1 gear reverse, all synchronized |
| Fuel capacity | 662 litres |

PEINTURES ESSENTIELLES / ESSENTIAL PAINTS



PEINTURES COMPLEMENTAIRES / ADDITIONAL PAINTS



Disponibles séparément chez votre revendeur de maquettes. / Available separately at you local hobby shop.

79894-176

a • M4A2 n° 27, "VALSERINE", 2ème DB, 12ème RCA

b • M4A2 n° 24, "CHAMPAUBERT", 2ème DB, 501ème RCC

c • M4A2 n° 40, "BRIVES LA GAILLARDE", 2ème DB, 12ème CUIR

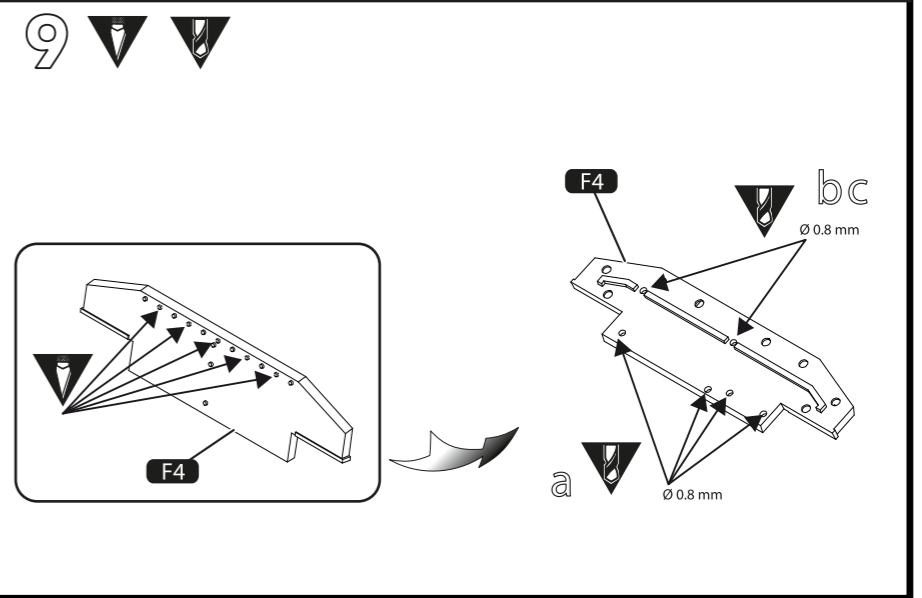
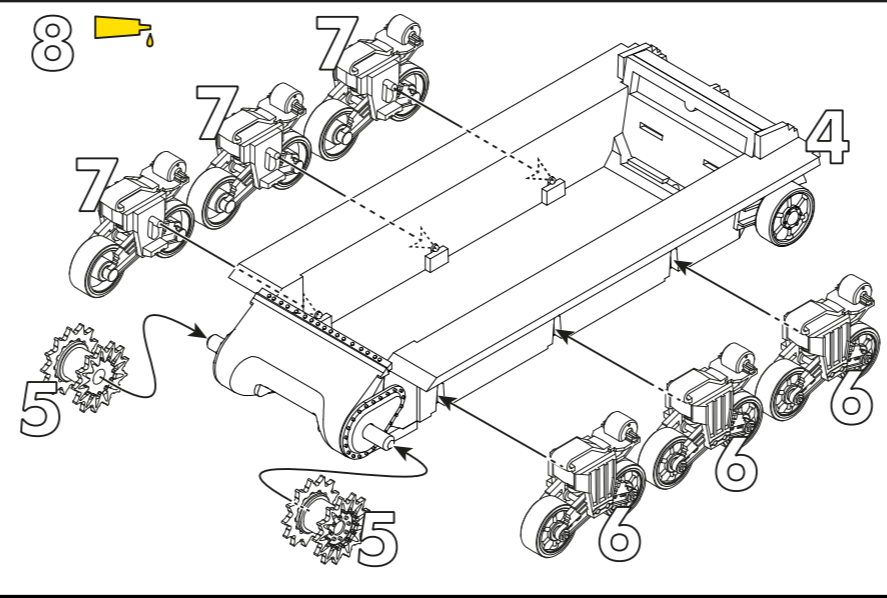
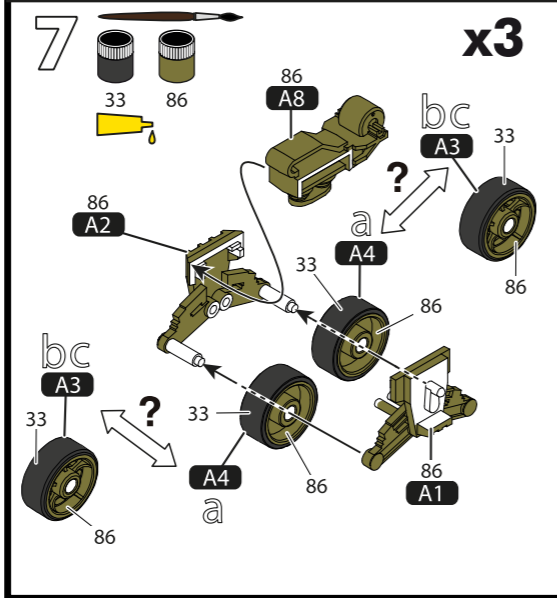
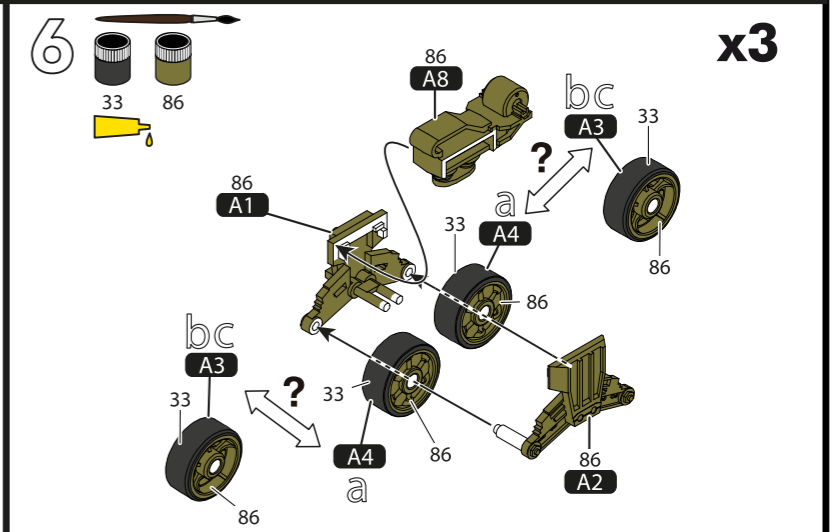
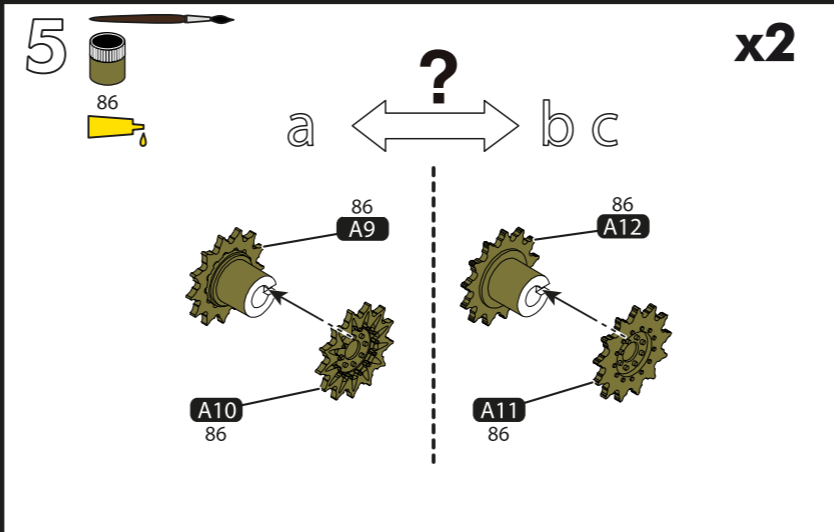
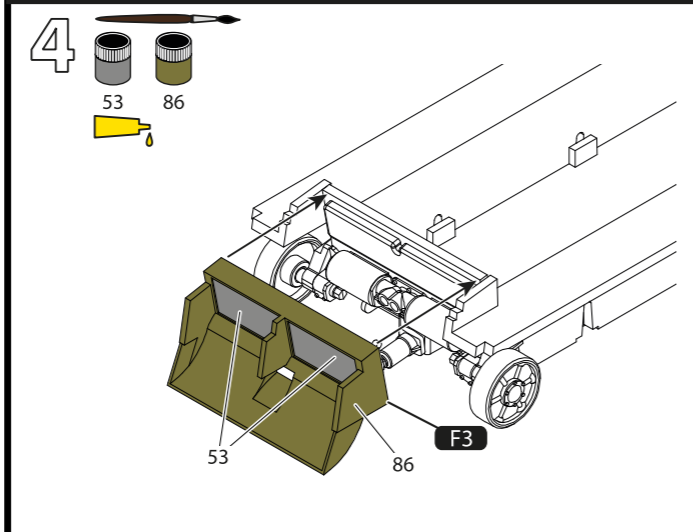
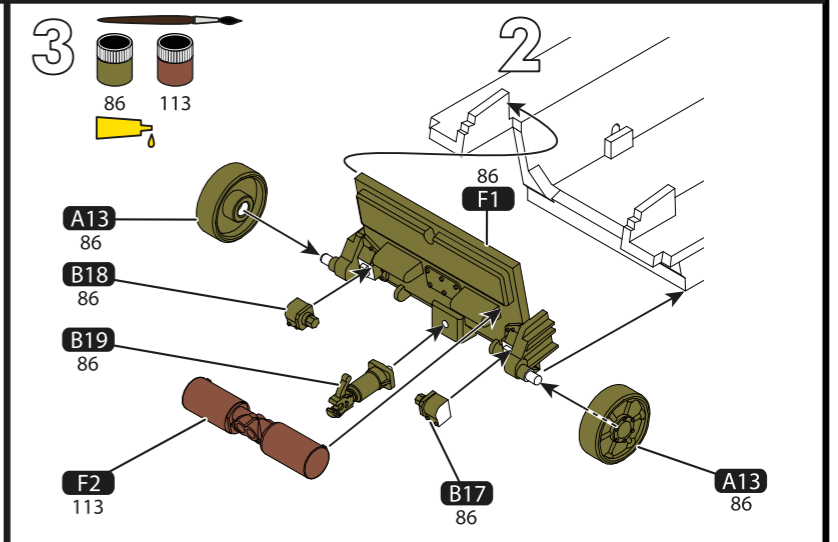
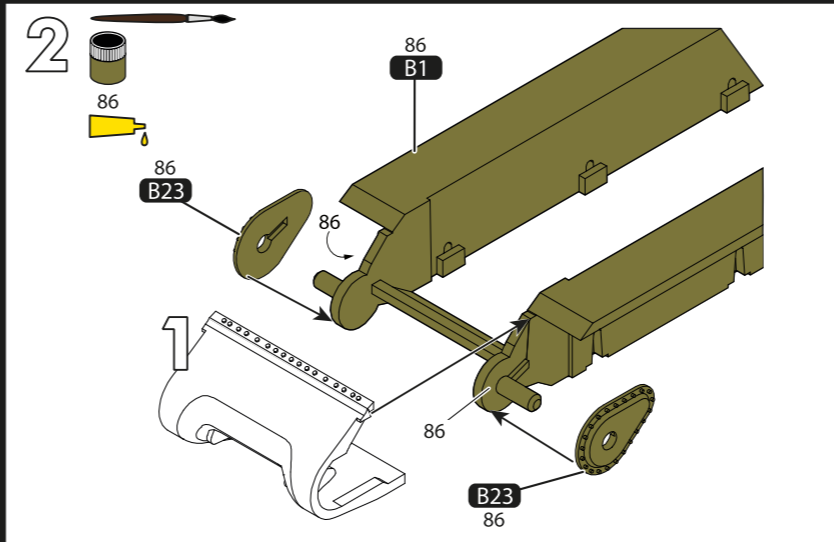
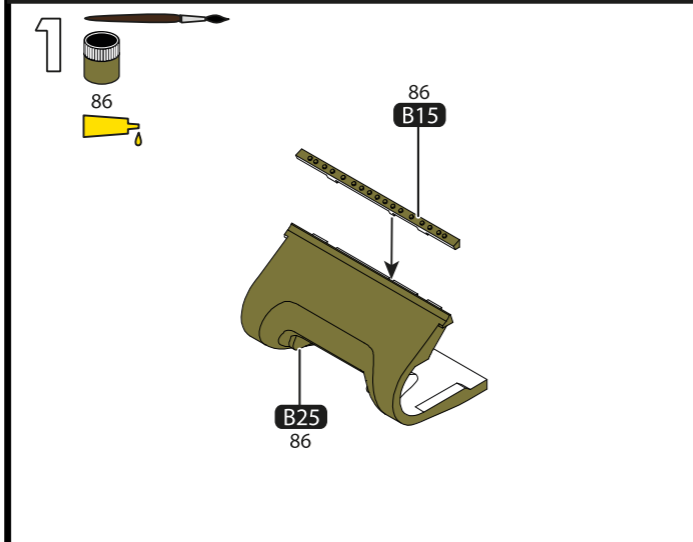

Deutsch

Der Sherman ist der mittlere amerikanische Panzer, der während des Zweiten Weltkrieges am meisten produziert wurde: Fast 55.000 Exemplare wurden in sehr verschiedenen Versionen hergestellt. Der mittlere M4 Sherman bildete die Hauptachse der alliierten Panzerstreitkräfte. Die fünf Hauptversionen vom M4 bis zum M4A4 unterscheiden sich hauptsächlich durch die verwendete Karosserieart, die Kanone und den Motor. Nach der ersten Kampfprobe wurden zusätzliche Panzerplatten jeder Seite der Wanne, der rechten Seite des Geschützturms und der abgeschrägten Vorderfront hinzugefügt. Die M4A2 profitierten von einem General Motors Dieselmotor mit 13,7 Liter Hubraum, dem GM 6-71. Obwohl nur mit einem 75-mm-Geschütz versehen, der anderen Panzergeschützen unterlegen war, glich der M4 dieses Ungleichgewicht durch seine Beweglichkeit, seine Zuverlässigkeit und vor allem durch seine zahlenmäßige Überlegenheit aus. Als Standardpanzer der Alliierten wurde der Sherman an allen Fronten bis zum Ende des Krieges eingesetzt. Er spielte eine entscheidende Rolle bei der Landung in der Normandie 1944 und während der Schlacht in der Normandie.

Länge der Wanne 5,92 m

Breite 2,62 m

Höhe 2,74 m

Gefechtsgewicht 31.800 kg

Panzerung Min. 25 mm
Max. 89 mm

Besatzung 5 Mann

Hauptbewaffnung 1 x M34A1 75-mm-Kanone

Sekundärbewaffnung 1 x M2 HB 12,7-mm-MG
2 x M1919A4 7,62-mm-MG
1 M3 Zwei-Zoll-Mörser für Rauchbomben

Motor GM 6-71

Getriebe 5 Vorwärtsgänge, 1 Rückwärtsgang, alle synchronisiert

Kraftstoffvorrat 662 Liter

Español

El Sherman es el carro de combate medio americano más producido durante la Segunda Guerra Mundial: se fabricaron cerca de 55.000 ejemplares en versiones muy variadas. El carro medio M4 Sherman constituyó la espina dorsal de la fuerza blindada aliada. Las cinco variantes principales de la M4 a la M4A4 se diferencian principalmente por el tipo de caja, el cañón y el motor utilizados. Después de la primera ronda de combates, se agregaban placas de blindaje suplementarias a cada lado del casco, a la derecha de la torreta y sobre la fortificación delantera. Los M4A2 se benefician de un motor diésel General Motors de 13,7 litros de cilindrada, el GM 6-71. A pesar de disponer de un cañón de 75mm superado por los cañones de los panzers, el M4 compensa este desequilibrio por su movilidad, su fiabilidad y sobre todo su superioridad numérica. El carro de combate estándar de los Aliados, el Sherman, se utilizará en todos los frentes hasta el final del conflicto. Tendrá un papel capital durante el Desembarco de 1944 y la batalla de Normandía.

Longitud del casco 5,92m

Anchura 2,62 m

Altura 2,74 m

Peso en orden de combate 31.800 kg

Blindaje Mín.: 25 mm
Máx.: 89 mm

Tripulación 5 hombres

Arma primaria 1 cañón de 75mm M34A1

Arma secundaria 1 ametralladora de 12,7 mm M2 HB
2 ametralladoras de 7,62 mm M1919A4
1 mortero M3 de 2 pulgadas para proyectiles fumígenos

Motor Continental R975 C1, 9 cilindros en estrella, enfriamiento por aire, 16 litros, 400 CV por 2400 t/m

Caja de velocidades 5 velocidades de avance y 1 de retroceso, todas sincronizadas

Capacidad de combustible 662 litros

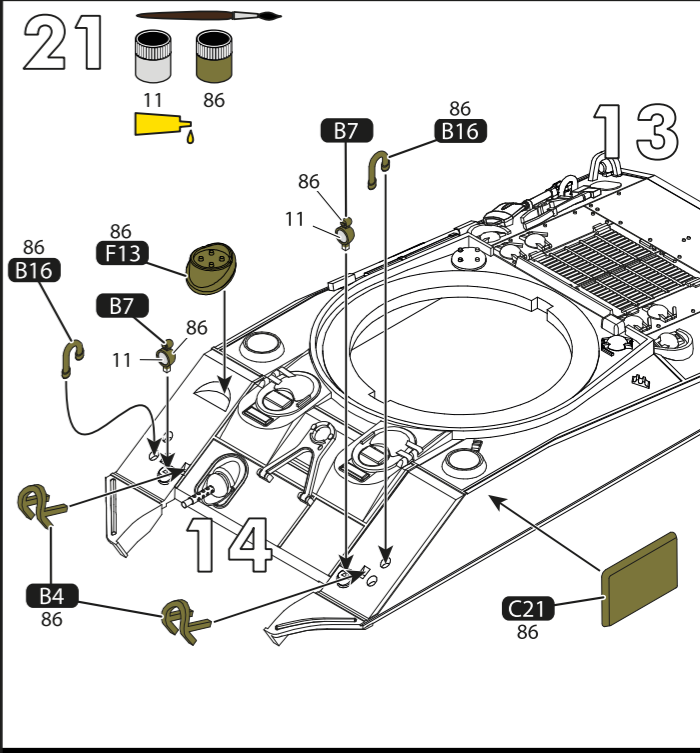
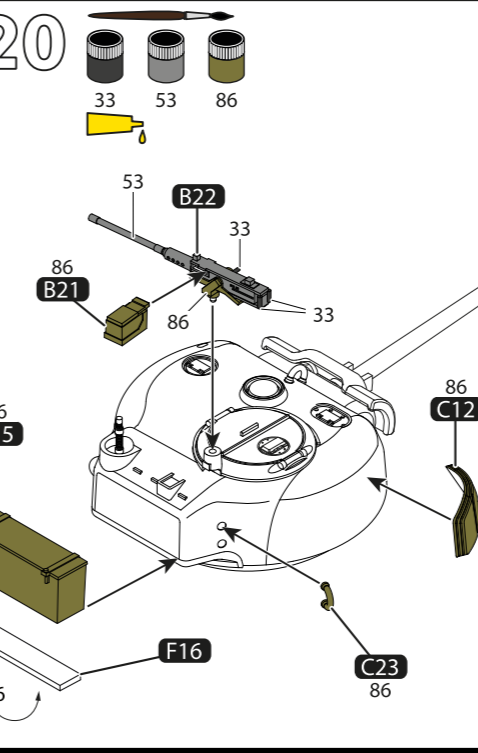
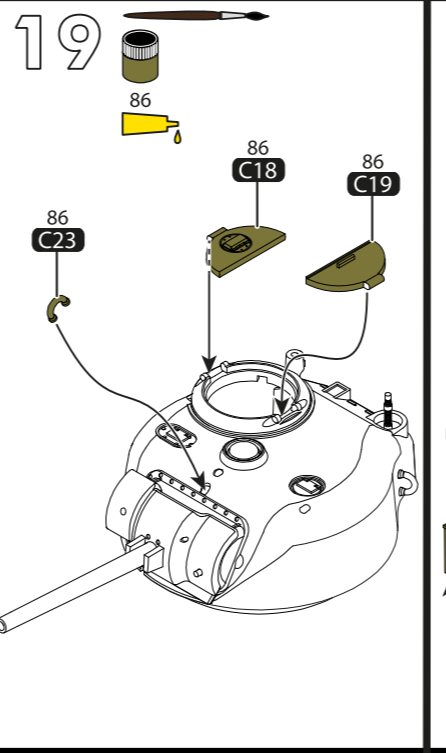
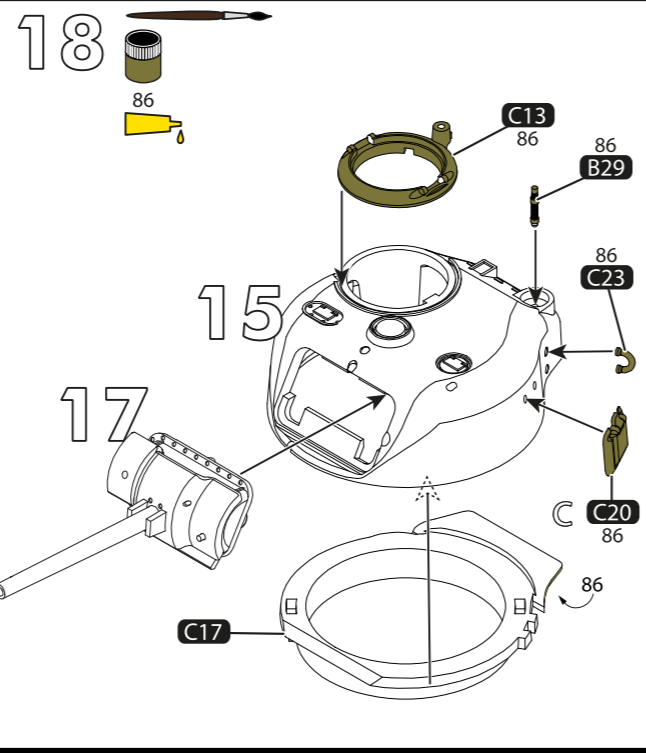
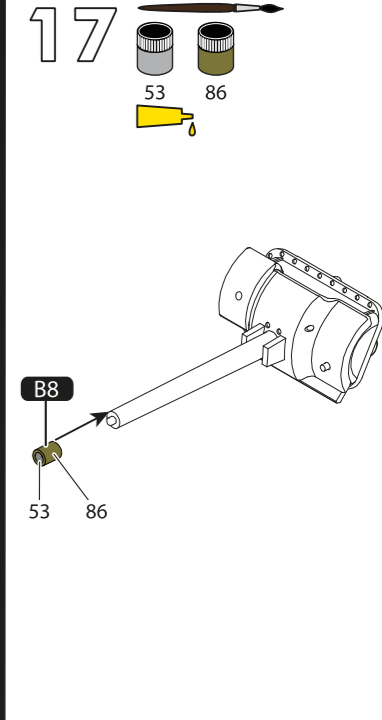
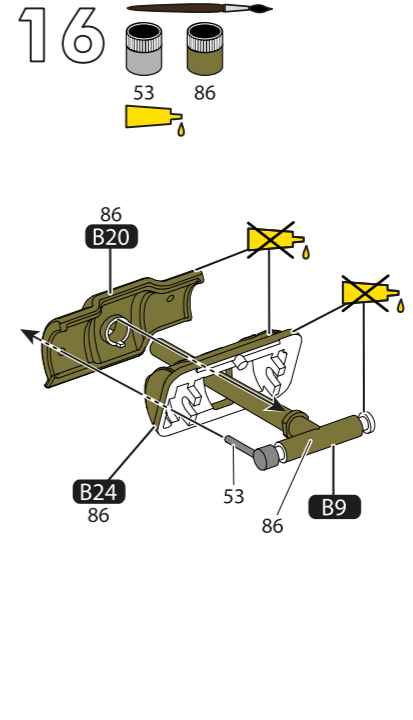
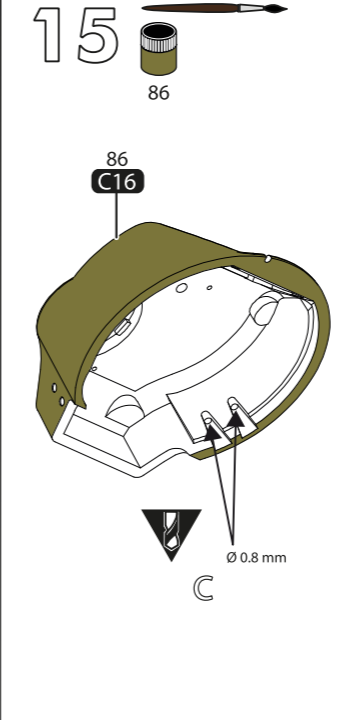
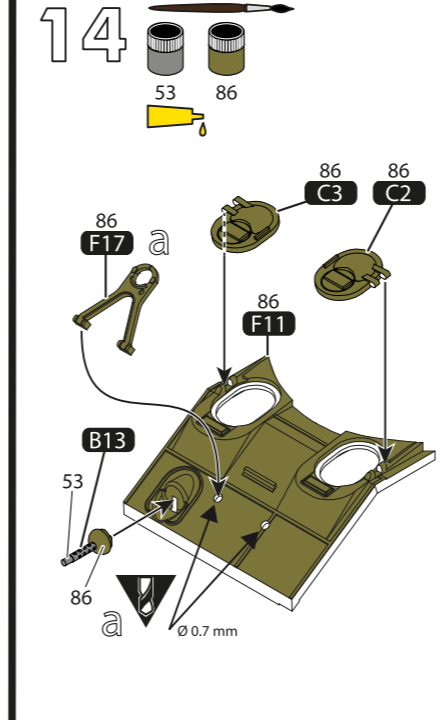
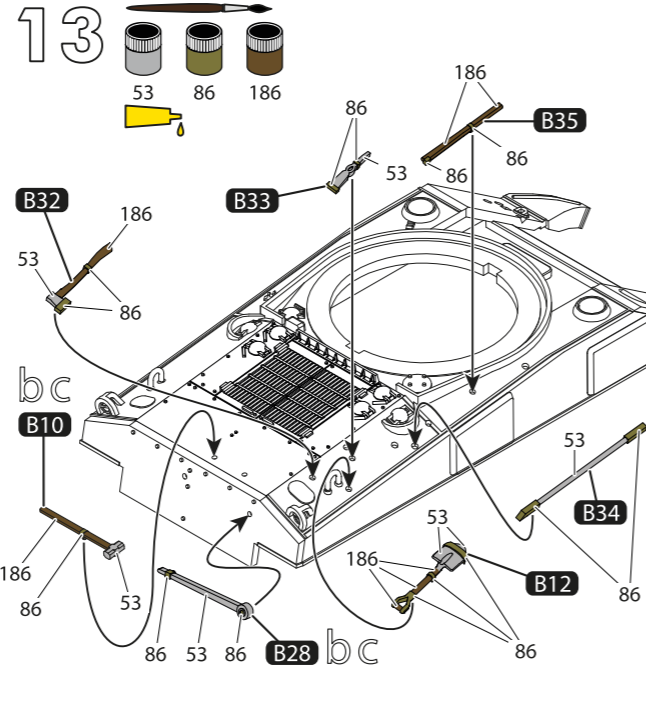
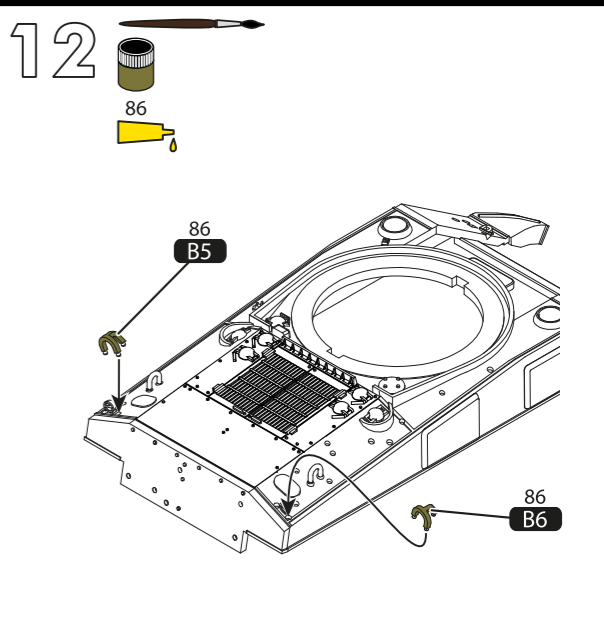
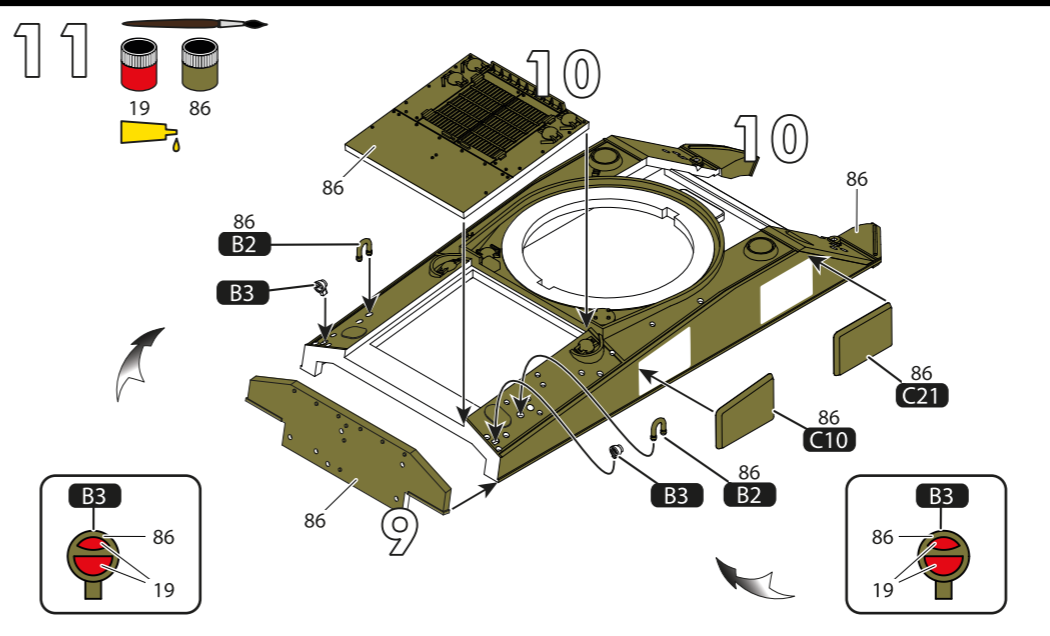
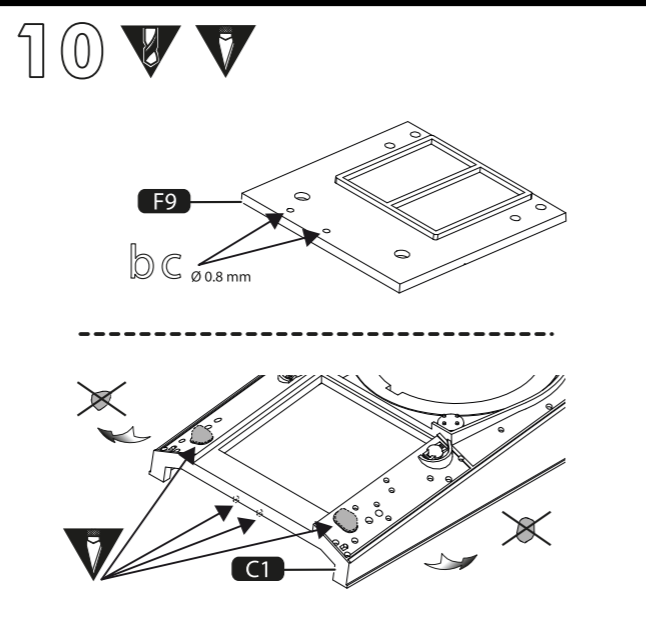

Italiano

Lo Sherman è il carro armato medio più prodotto durante la Seconda Guerra mondiale: ne furono infatti realizzati circa 55.000 esemplari, in diverse versioni. Il carro medio M4 Sherman rappresentava la spina dorsale delle forze blindate alleate. Le cinque varianti principali da M4 a M4A4 si differenziavano principalmente per tipo di cassa, cannone e motore utilizzato. Dopo la prima prova di combattimento verranno aggiunte delle ulteriori placche di corazzatura su ogni lato dello scafo, a destra della torretta e sulla parte inclinata anteriore. Gli M4A2 utilizzano un motore diesel General Motors da 13,7 litri di cilindrata, il GM 6-71. Poiché dispone solo di un cannone 75 mm, surclassato dai cannoni dei panzer, il M4 compensa questo svantaggio con una grande mobilità, affidabilità e soprattutto superiorità numerica. Mezzo armato standard degli Alleati, lo Sherman sarà impiegato su tutti i fronti fino alla fine del conflitto, rivestendo un ruolo chiave nello sbarco del 1944 e durante la battaglia di Normandia.

| | |
|--|--|
| Lunghezza scafo | 5,92m |
| Larghezza | 2,62 m |
| Altezza | 2,74 m |
| Peso in ordine di combattimento | 31800 kg |
| Corazzatura | Min: 25 mm Max: 89 mm |
| Equipaggio | 5 uomini |
| Armamento primario | 1 cannone da 75 mm M34A1 |
| Armamento secondario | 1 mitragliatrice da 12,7 mm M2 HB 2 mitragliatrici da 7,62 mm M1919A4 1 mortaio M3 da 2 pollici per fumogeni |
| Motorizzazione | GM 6-71 |
| Cambio | 5 velocità in avanti, 1 retromarcia, tutte sincronizzate |
| Capacità carburante | 662 litri |

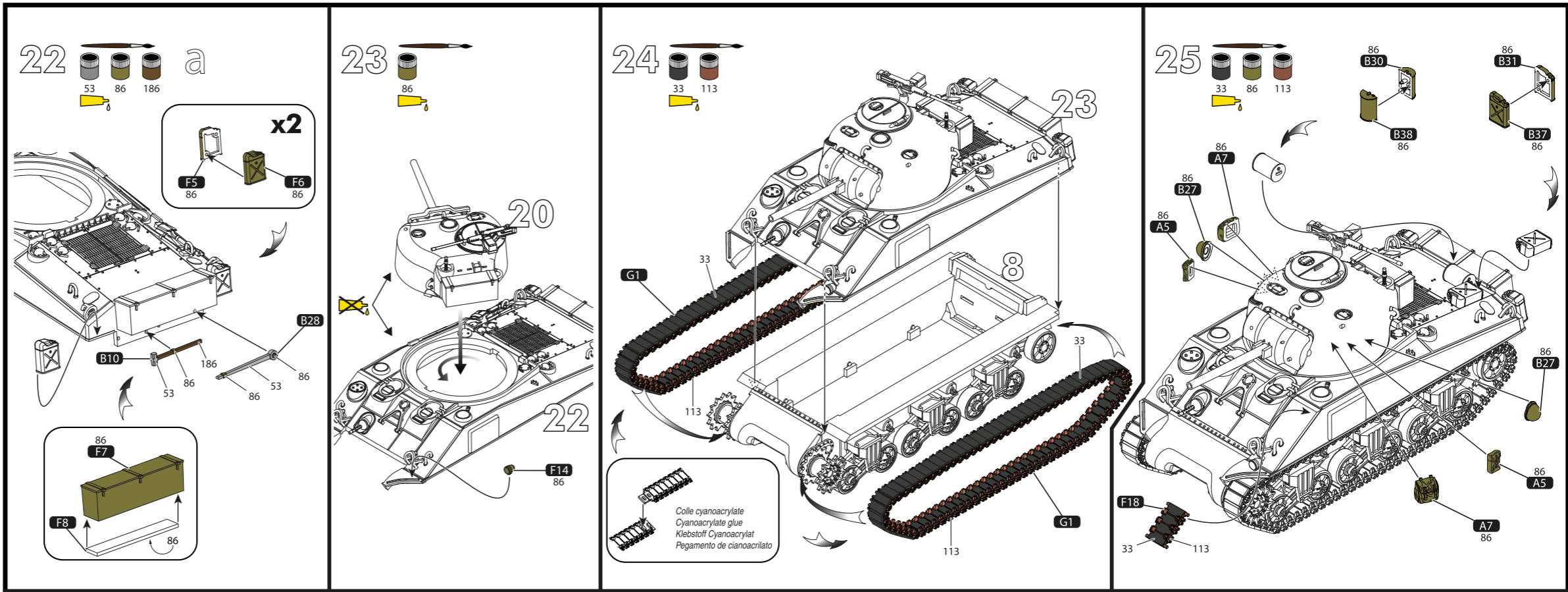

Nederlands

De Amerikaanse middelzware tank, de Sherman, was de meest gefabriceerde tank tijdens de Tweede Wereldoorlog: er werden circa 55000 stuks in zeer verschillende versies gemaakt. De middelzware tank M4 Sherman was de ruggengraat van de geallieerde pantsermacht. De vijf belangrijkste varianten, van de M4 tot de M4A4, verschillen in het bijzonder door het gebruikte type van carrosserie, kanon en motor. Na de eerste gevechtstesten met de tank, werden er extra pantserplaten aan elke kant van de carrosserie, de rechterkant van de pantserkoepel en op het hellend vlak vooraan toegevoegd. De M4A2 was uitgerust met een General Motors dieselmotor met een cilinderhoud van 13,7 liter, de GM 6-71. Hoewel zijn 75 mm kanon door de kanonnen op de pantsertanks ruimschoots werd overtroffen, werd dit gecompenseerd door zijn mobiliteit, zijn betrouwbaarheid en bovenal door zijn numerieke overwicht. De Sherman, de standaard tank bij de Geallieerden, werd tot aan het einde van het conflict op alle fronten gebruikt. Hij speelde een belangrijke rol tijdens de D-day Landing van 1944 en de Slag van Normandië.

| | |
|-----------------------------|---|
| Lengte carrosserie | 5,92m |
| Breedte | 2,62 m |
| Hoogte | 2,74 m |
| Gevechtsgewicht | 31800 kg |
| Bepantsering | Min: 25 mm Max: 89 mm |
| Bemanning | 5 personen |
| Voornaamste wapening | 175mm M34A1 kanon |
| Aanvullende wapening | 1 12,7 mm M2 HB mitrailleur 2 7,62 mm M1919A4 mitrailleurs 1 M3 motier van 2 duimen voor rookbommen |
| Motorisering | GM 6-71 |
| Versnellingsbak | 5 versnellingen vooruit, 1 achteruit, allen gesynchroniseerd |
| Inhoud brandstoftank | 662 litri |

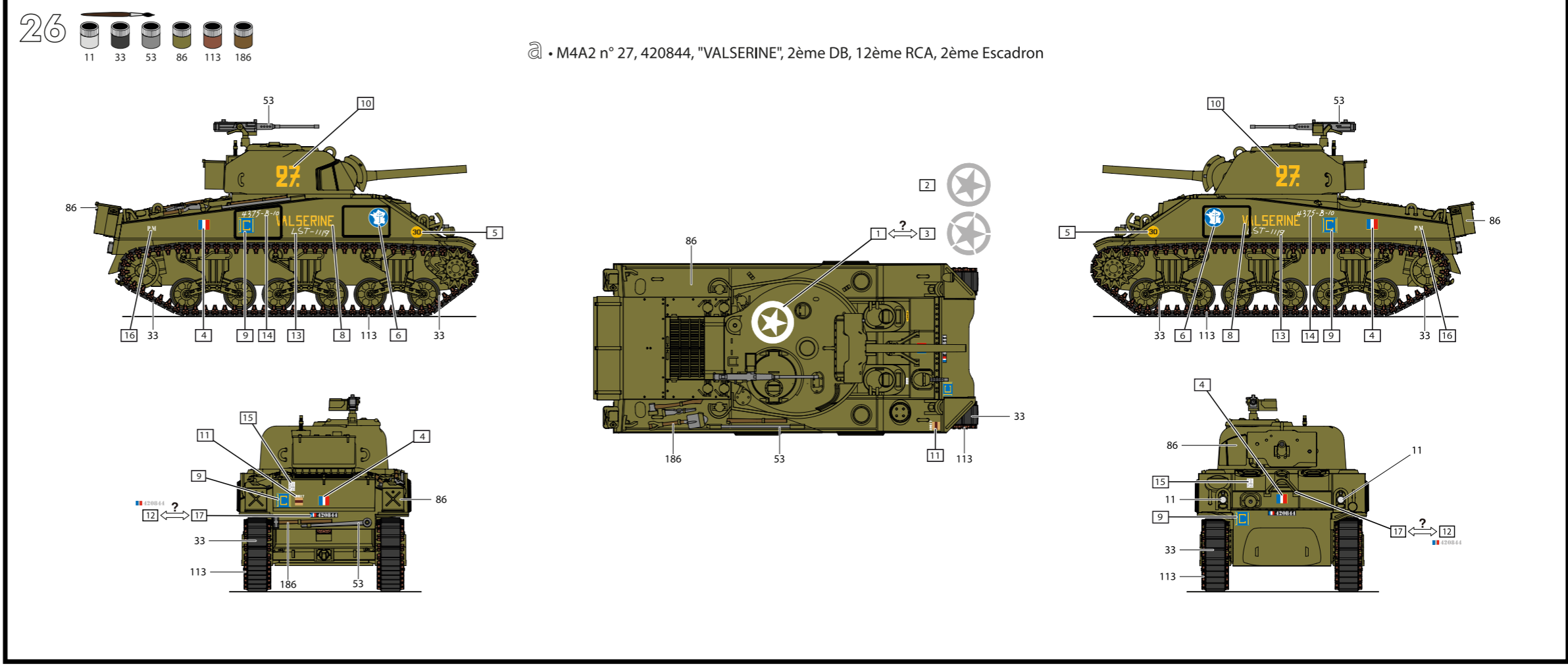

• M4A2 n° 27, 420844, "VALSERINE", 2ème DB, 12ème RCA, 2ème Escadron

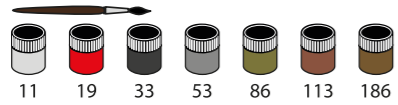

b • M4A2 n° 24, "CHAMPAUBERT", 2ème DB, 501ème RCC

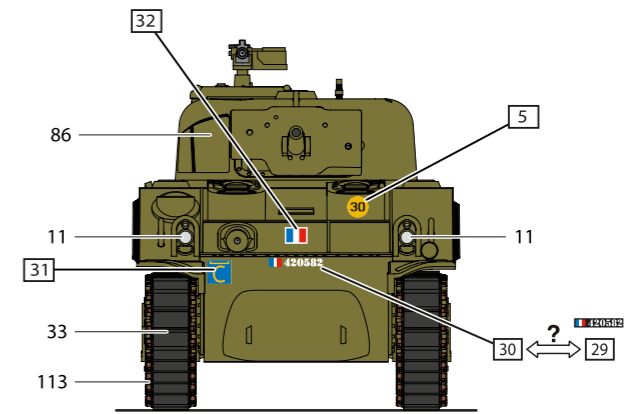
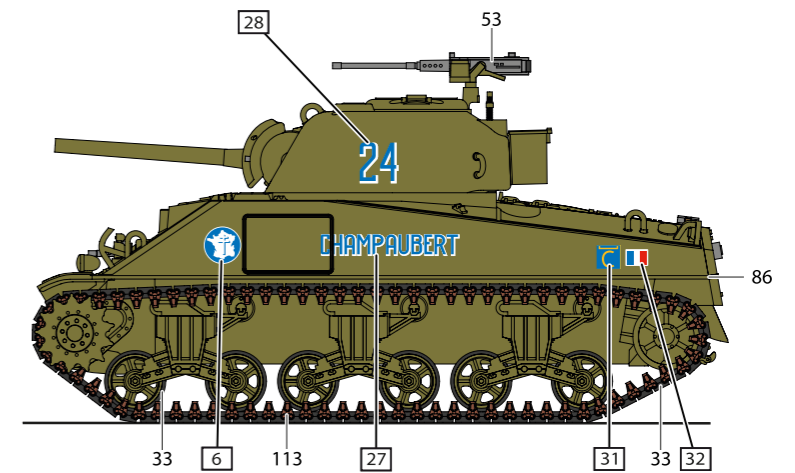
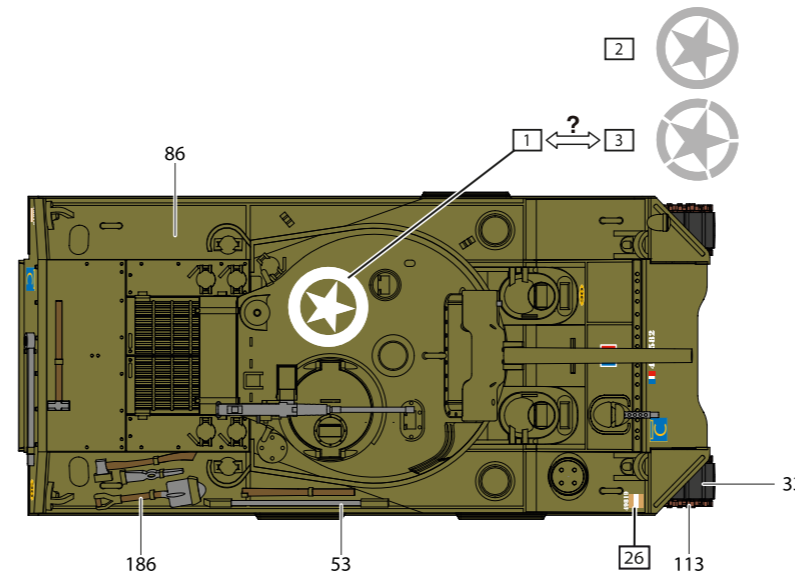
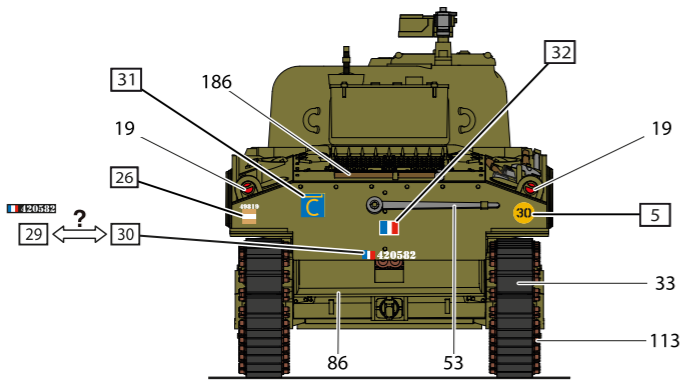
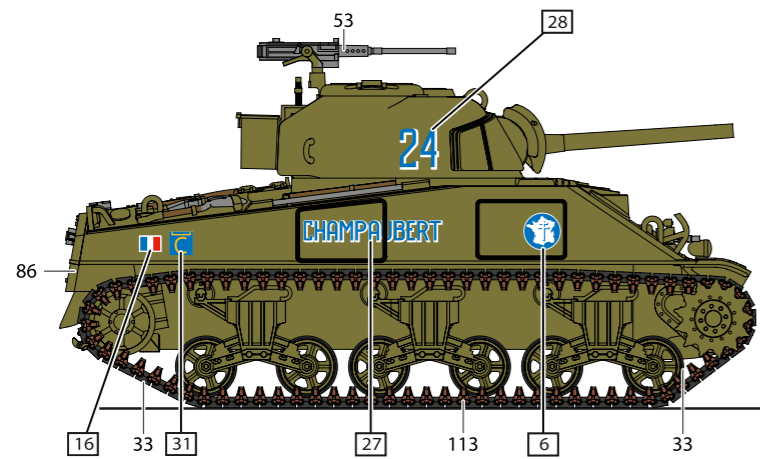

c • M4A2 n° 40, "BRIVES LA GAILLARDE", 2ème DB, 12ème CUIR

